



Operator's Manual

S-100

S-105

S-120

S-125

ANSI/CSA
North America
South America
Asia

AUS
Australia

with
Maintenance
Information

Fifth Edition
Second Printing
Part No. T111108

Important

Read, understand and obey these safety rules and operating instructions before operating this machine. Only trained and authorized personnel shall be permitted to operate this machine. This manual should be considered a permanent part of your machine and should remain with the machine at all times. If you have any questions, call Genie Industries.

Contents

Page	
Introduction	1
Symbol and Hazard Pictorials Definitions	3
General Safety	5
Personal Safety	11
Work Area Safety	12
Legend	22
Controls	23
Inspections	31
Operating Instructions	50
Transport and Lifting Instructions	60
Maintenance	63
Specifications	66

Contact us:

Internet: <http://www.genielift.com>
E-mail: techpub@genieind.com

Copyright © 2000 by Genie Industries

Fifth Edition: Second Printing, January 2012

"Genie" is a registered trademark of Genie Industries in the U.S.A. and many other countries. "S" is a trademark of Genie Industries.

These machines comply with
ANSI/SIA 92.5
CAN B.354.4
AUS 1418.10

 Printed on recycled paper

Printed in U.S.A.

Introduction

Owners, Users and Operators:

Genie appreciates your choice of our machine for your application. Our number one priority is user safety, which is best achieved by our joint efforts. We feel that you make a major contribution to safety if you, as the equipment users and operators:

- 1 **Comply** with employer, job site and governmental rules.
- 2 **Read, understand and follow** the instructions in this and other manuals supplied with this machine.
- 3 **Use good safe work practices** in a commonsense way.
- 4 **Only have trained/certified operators**, directed by informed and knowledgeable supervision, running the machine.

If there is anything in this manual that is not clear or which you believe should be added, please contact us.

Internet: www.genielift.com

E-mail: techpub@genieind.com



Danger

Failure to obey the instructions and safety rules in this manual will result in death or serious injury.

Do Not Operate Unless:

- You learn and practice the principles of safe machine operation contained in this operator's manual.
 - 1 **Avoid hazardous situations.**
Know and understand the above principle before going on to the next section.
 - 2 Always perform a pre-operation inspection.
 - 3 Always perform function tests prior to use.
 - 4 Inspect the workplace.
 - 5 Only use the machine as it was intended.
- You read, understand and obey the manufacturer's instructions and safety rules—safety and operator's manuals and machine decals.
- You read, understand and obey employer's safety rules and worksite regulations.
- You read, understand and obey all applicable governmental regulations.
- You are properly trained to safely operate the machine.

Introduction

Hazard Classification

Genie uses symbols, color coding and signal words to identify the following:



Safety alert symbol—used to alert you to potential personal injury hazards. Obey all safety messages that follow this symbol to avoid possible injury or death.

▲ DANGER

Red

Indicates a hazardous situation which, if not avoided, will result in death or serious injury.

▲ WARNING

Orange

Indicates a hazardous situation which, if not avoided, could result in death or serious injury.

▲ CAUTION

Yellow

Indicates a hazardous situation which, if not avoided, could result in minor or moderate injury.

NOTICE

Blue

Indicates a property damage message.



















Intended Use

This machine is intended to be used only to lift personnel, along with their tools and materials to an aerial work site.

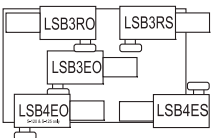





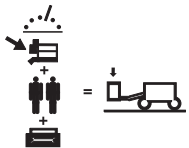





Safety Sign Maintenance

Replace any missing or damaged safety signs. Keep operator safety in mind at all times. Use mild soap and water to clean safety signs. Do not use solvent-based cleaners because they may damage the safety sign material.

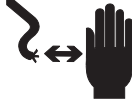
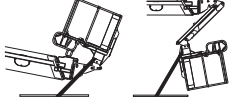
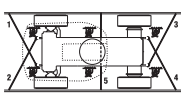
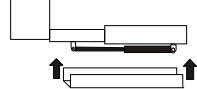
Symbol and Hazard Pictorials Definitions

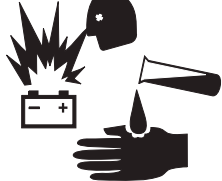
 <p>Crush Hazard</p>	 <p>Keep away from moving parts.</p>	 <p>Explosion Hazard</p>	 <p>No smoking. No flame. Stop engine.</p>	 <p>Electrocution Hazard</p>
 <p>Maintain required clearance.</p>	 <p>Crush Hazard</p>	 <p>Keep away from path of moving platform.</p>	 <p>Fall Hazard</p>	 <p>Keep off this surface.</p>
 <p>Only trained maintenance personnel should access compartments.</p>	 <p>Read the operator's manual.</p>	 <p>Do not alter or disable limit switch(es)</p>	 <p>Tip-over Hazard</p>	 <p>Fall Hazard</p>
 <p>Tip-over Hazard</p>	<p>Recovery procedure if tilt alarm sounds while elevated.</p> <div style="display: flex; justify-content: space-around;"> <div data-bbox="440 1377 651 1665">  <p>Platform downhill:</p> <ol style="list-style-type: none"> 1. Retract boom. 2. Lower boom. </div> <div data-bbox="691 1377 902 1665">  <p>Platform uphill:</p> <ol style="list-style-type: none"> 1. Lower boom. 2. Retract boom. </div> </div>		 <p>Tip-over Hazard</p>	 <p>Do not overload platform. Welder power supply weighs 75 lb / 34 kg</p>

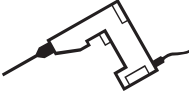
Symbol and Hazard Pictorials Definitions

 <p>Lanyard attachment point</p>	 <p>Wheel load</p>	 <p>Fire Hazard</p>	 <p>Have fire extinguisher near.</p>	 <p>Replace tires with same tire.</p>
 <p>Electrocution Hazard</p>	 <p>Avoid contact.</p>	 <p>Tie-down instructions</p>	 <p>Tie-down instructions</p>	 <p>Replace extension cylinder cover before operating machine.</p>
 <p>Explosion Hazard</p>	 <p>Do not use ether or other high energy starting aids on machines equipped with glow plugs.</p>	 <p>Explosion / Burn Hazard</p>	 <p>Keep all open flames and sparks away.</p>	 <p>No Step</p>
 <p>Voltage rating for power to platform</p>	 <p>Pressure rating for air line to platform</p>	 <p>Read service manual.</p>		

General Safety

114389

▲ DANGER

Failure to read, understand and obey the operator's manual and the following safety rules will result in death or serious injury.

Improper Use Hazard

The operator is responsible for safe machine operation. This includes:

1. Avoid hazardous situations.
2. Always perform a pre-operation inspection.
3. Always perform function tests prior to use.
4. Inspect work place.
5. Only use the machine as it was intended.

Do not operate under:

- You read, understand and obey:
 - manufacturer's instructions and safety rules — safety and operators' manuals and decide whether a safety idea
 - applicable governmental regulations

You are properly trained to safely operate this machine.

Electrocution Hazards

This machine is not electrically insulated and will not provide protection from contact with or proximity to electrical current.

Line Voltage	Required Clearance
0 to 50kV	10 ft. 3.2 m
50 to 100kV	15 ft. 4.6 m
100 to 200kV	20 ft. 6.1 m
200 to 350kV	25 ft. 7.6 m
350 to 500kV	35 ft. 10.6 m
500 to 1000kV	45 ft. 13.7 m

Tip-over Hazards

Do not raise or extend booms unless machine is on firm, level ground.

Do not depend on 18 alarm as a bell warning. 18 alarm sounds in platform only when machine is on a severe slope.

Do not raise boom when wind speeds may exceed 28 mph (11.2 m/s).

Do not operate machine in strong or gusty winds. Do not increase surface area of platform or load. Decreasing area exposed to wind will decrease machine stability.

Do not drive machine on or near uneven terrain, unstable surfaces or other hazardous conditions with boom raised or extended.

Do not drive machine on a slope that exceeds the maximum slope or side slope rating for the machine.

Use extreme care and slow speeds when driving the machine in forward position across uneven terrain, ditches, curbs or sloped surfaces and near trucks and drop-offs.

Do not attempt to lift or engage platform using platform controls. All personnel must be removed from platform before attempting to raise platform using ground controls.

Do not use machine on a moving or mobile surface or vehicle.

Be sure all tires are in good condition, and all tires are properly inflated and kept near an evenly lightedness.

Fall Hazards

Operators must wear a safety belt or harness in accordance with governmental regulations. Always lanyard to anchor provided in platform.

Do not sit, stand or climb on the platform guard rails.

Maintain a firm footing on the platform floor at all times.

Do not climb down from the platform when raised.

Lower the platform entry inside or close the entry gate before operating.

Collision Hazards

Be aware of faster sight distances and blind spots when driving or operating.

Check work area for overhead obstructions or other possible hazards.

Be aware of crushing hazard when grasping the platform guard rail.

Do not use a crane or other hoisted device unless on the platform control and all other devices for drive and steer functions.

Do not lower the boom unless the area below is clear of personnel and obstructions.

Explosion Hazard

Do not start engine if you smell or detect liquid petroleum gas (LPG), gasoline, diesel fuel or other explosive substances.

Do not refuel the machine with the engine running.

Damaged Machine Hazards

Do not use a damaged or malfunctioning machine.

Be sure all maintenance has been performed as specified in the appropriate operator's and service manuals.

Be sure all work is in place and tight.

Be sure safety, operator's and responsibilities manuals are complete, legible and in the storage container located on the platform.

28161

▲ WARNING

Crush Hazard
Contact with moving parts can result in death or serious injury.

Keep away from moving parts.

28177

▲ WARNING

Crush Hazard
Death or serious injury may result from platform crushing personnel against boom.

Keep away from path of moving platform.

65428

▲ DANGER

Tip-over Hazard
Failure to replace foam-filled tires with tires of same specification will cause death or serious injury.

Tires are critical to machine stability. Do not replace original factory-installed tires with tires of different specification or ply rating.

82902

▲ DANGER

Tip-over Hazard
Altering or disabling limit switches can result in machine tip-over. Machine tip-over will result in death or serious injury.

Do not alter or disable limit switch(es).

LSBPRO: Operational limit switch for >=100 foot length

LSB2RS: Safety limit switch for 100 foot length

82237

▲ DANGER

Electrocution Hazard
Contact with energized components can result in death or serious injury.

Avoid contact with energized components.

97875

▲ WARNING

Electrocution Hazard
Failure to properly connect and use the weld line to platform could result in death or serious injury.

Read, understand and obey all warnings and instructions provided with welding power unit.

Turn welding power unit off before connecting leads.

Be sure weld cables are properly connected.

DC weld only: 40V, 300 amp maximum.

Component Damage Hazard
Failure to properly connect weld leads may result in machine or component damage.

Turn welding power unit off before connecting leads.

Connect leads to twist-lock connectors at turntable and platform.

114390

▲ DANGER

Electrocution Hazard
Death or injury can result from contacting electric power lines.

Always contact the electric power line owner. The electric power shall be disconnected or the power lines moved or insulated before machine operations begin.

Line Voltage	Required Clearance
0 to 50kV	10 ft. 3.2 m
50 to 100kV	15 ft. 4.6 m
100 to 200kV	20 ft. 6.1 m
200 to 350kV	25 ft. 7.6 m
350 to 500kV	35 ft. 10.6 m
500 to 1000kV	45 ft. 13.7 m

T114285

▲ WARNING

Fall Hazard / Impact Hazard
Falling and/or contact with bucket after boom collapse can result in death or serious injury.

Install the secondary extend cylinder cover before operating machine. Refer to service manual.

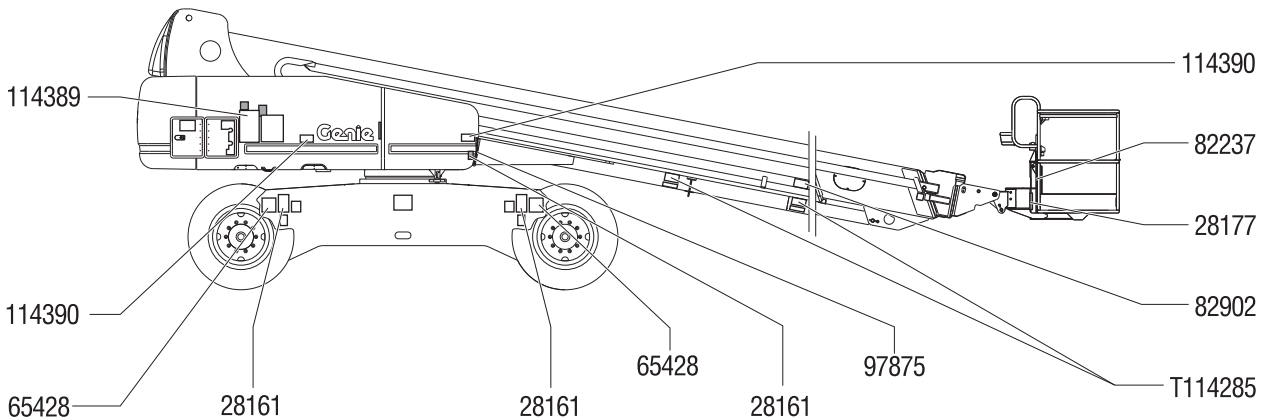

General Safety

114389

⚠ DANGER

Failure to read, understand and obey the operator's manual and the following safety rules will result in death or serious injury. Improper Use Hazard

The operator is responsible for safe machine operation. This includes:

1. Avoid hazardous situations.
2. Always perform a pre-operation inspection.
3. Always perform function tests prior to use.
4. Inspect work place.
5. Only use the machine as it was intended.

Do not operate unless:

You read, understand and obey:

- manufacturer's instructions and safety rules — safety and operator's manuals and decals
- employer's safety rules
- applicable governmental regulations

You are properly trained to safely operate this machine.

Electrocution Hazards

This machine is not electrically insulated and will not provide protection from contact with or proximity to electrical current.

Line Voltage	Required Clearance
0 to 1000V	10 ft / 3.0 m
50 to 2000V	15 ft / 4.6 m
250 to 3000V	20 ft / 6.1 m
350 to 3500V	25 ft / 7.6 m
500 to 7500V	35 ft / 10.6 m
750 to 15000V	45 ft / 13.7 m

Tip-over Hazards

Do not raise or extend boom unless machine is on firm, level ground.

Do not depend on tilt alarm as a level indicator. Tilt alarm sounds on platform only when machine is on a severe slope.

Do not raise boom when wind speeds may exceed 28 mph / 12.5 m/s.

Do not operate machine in strong or gusty winds. Do not increase surface area of platform or load, increasing area exposed to wind will decrease machine stability.

Do not drive machine on or near uneven terrain, unstable surfaces or other hazardous conditions with boom raised or extended.

Do not drive machine on a slope that exceeds the maximum slope or side slope rating for the machine.

Use extreme care and slow speeds while driving the machine in sloped position across uneven terrain, stairs, unstable or slippery surfaces and near holes and drop-offs.

Do not attempt to free a caught or snagged platform using platform controls. All personnel must be removed from platform before attempting to free platform using ground controls.

Do not alter or disable machine components that in any way affect safety and stability.

Be sure all tires are in good condition, and that tires are properly inflated and lug nuts are properly tightened.

Do not push off or pull toward any object outside of the platform.

Do not place or attach overhanging loads to any part of this machine.

Do not place ladders or scaffolds in platform or against any part of this machine.

Do not use machine on a moving or mobile surface or vehicle.

Occupants must wear a safety belt or harness in accordance with governmental regulations. Attach lanyard to anchor provided in platform.

Do not sit, stand or climb on the platform guard rails. Maintain a firm footing on the platform floor at all times.

Do not climb down from the platform when raised.

Lower the platform entry mid-rail or climb the entry gate before operating.

Be aware of limited sight distance and blind spots when driving or operating.

Check work area for overhead obstructions or other possible hazards.

Be aware of crushing hazard when grasping the platform guard rail.

Observe and use color-coded direction arrows on the platform controls and drive chassis for drive and steer functions.

Do not lower the boom unless the area below is clear of personnel and obstructions.

Explosion Hazard

Do not start engine if you smell or detect liquid petroleum gas (LPG), gasoline, diesel fuel or other explosive substances.

Do not refuel the machine with the engine running.

Damaged Machine Hazards

Do not use a damaged or malfunctioning machine.

Be sure all maintenance has been performed as specified in the appropriate operator's and service manuals.

Be sure all decals are in place and legible.

Be sure safety, operator's and responsibilities manuals are complete, legible and in the storage container located on the platform.

114416

⚠ DANGER



Tip-over Hazard
If tilt-alarm sounds, unit is on a severe slope. Death or serious injury will result.



Stop all movement.



Platform uphill:
1 Lower boom.
2 Retract boom.



Read operator's manual before attempting to move machine.



Platform downhill:
1 Retract boom.
2 Lower boom.

97875

⚠ WARNING

Electrocution Hazard
Failure to properly connect and use the weld line to platform could result in death or serious injury.

Read, understand and obey all warnings and instructions provided with welding power unit.

Turn welding power unit off before connecting leads.

Be sure weld cables are properly connected.

DC weld only: 40V, 300 amp maximum.

Component Damage Hazard
Failure to properly connect weld leads may result in machine or component damage.

Turn welding power unit off before connecting leads.

Connect leads to twist-lock connectors at turntable and platform.

97875 A

28236

⚠ WARNING



Improper operation or maintenance can result in serious injury or death.



Read and understand Operator's Manual, Responsibilities Manual and Safety Manual and all safety signs before using or maintaining machine.

If you do not understand the information in the manuals, consult your supervisor, the owner or the manufacturer.

28236 D

82862

⚠ DANGER



Fire Hazard
Serious injury or death will result if fire occurs while operating welder and fire extinguisher is not available.



Do not operate welder unless fire extinguisher is immediately available for instant use, per OSHA regulation 1926.352(d).

82862 B

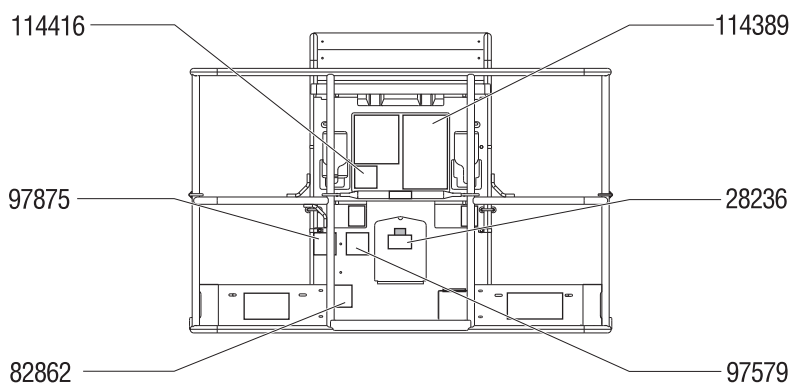

97579

⚠ DANGER



Tip-over Hazard
Welder power supply reduces rated platform capacity and must be factored into total platform load.

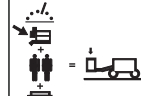

Do not overload platform.
Welder power supply weighs 75 lbs / 34 kg.

97579 C

82410

⚠ WARNING

Bodily Injury Hazard

Failure to use panel cradles according to instructions and safety rules below and in operator's and responsibilities manual could result in death or serious injury.

Do not exceed rated platform capacity. Combined weight of cradles, panels, occupants, tools and any other equipment must not exceed rated capacity.

Panel cradle assembly weighs 30 lbs / 13.6 kg. Maximum capacity of panel cradles is 250 lbs / 113 kg.

Weight of panel cradles and load in panel cradles may limit maximum number of occupants in platform to one person.

Secure cradles to platform. Secure panel(s) to platform railing using straps provided.

Do not operate unless you are adequately instructed and are aware of all hazards associated with lifting panels.

Do not cause a horizontal force or side load to machine by raising or lowering a fixed or overhanging load.

Maximum vertical height of panels: 4 ft / 1.2 m

Maximum wind speed: 15 mph / 6.7 m/sec

Maximum panel area: 32 sq. ft. / 3 m²

82410

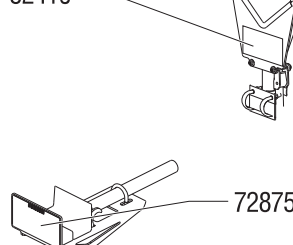

72875

⚠ WARNING

Bodily Injury Hazard

Failure to use pipe cradle assembly according to instructions and safety rules below and in operator's and responsibilities manual could result in death or serious injury.

Do not exceed rated platform capacity.

Pipe cradle assembly and weight in pipe cradles will reduce rated platform capacity and must be factored into total platform load.

Pipe cradle assembly weighs 21 lbs / 9.5 kg.

Maximum capacity of pipe cradle assembly is 200 lbs / 91 kg.

Weight of pipe cradle assembly and load in pipe cradles may limit maximum number of occupants in platform.

Center load within perimeter of platform.

Secure load to platform.

Do not obstruct entrance/exit of platform.

Do not obstruct ability to operate platform controls or red Emergency Stop button.

Do not operate unless you are adequately instructed and are aware of all hazards associated with movement of platform with overhanging load.

Do not cause a horizontal force or side load to machine by raising or lowering a fixed or overhanging load.

Electrocution Hazard: Keep pipes away from all energized electrical conductors.

General Safety

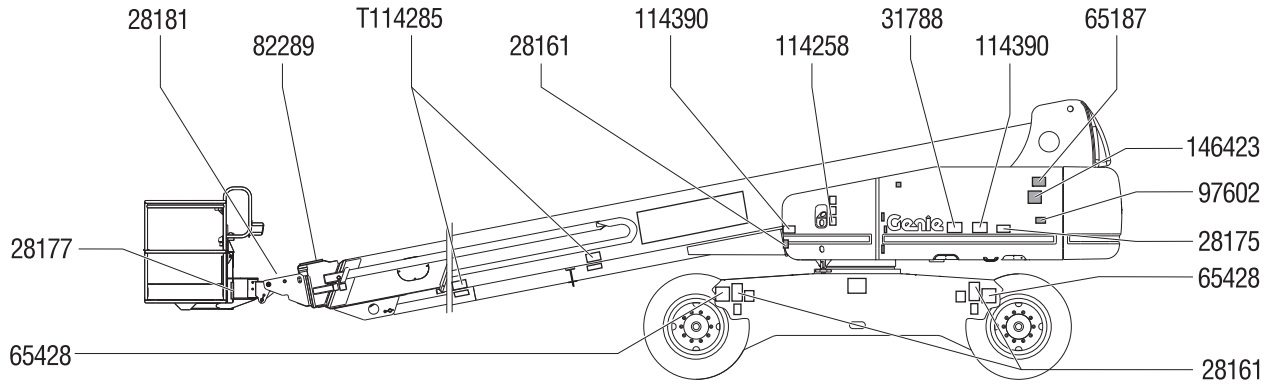

28177

WARNING

Crush Hazard
Death or serious injury may result from platform crushing personnel against boom.

Keep away from path of moving platform.

28177 C

28161

WARNING

Crush Hazard
Contact with moving parts can result in death or serious injury.

Keep away from moving parts.

28161 C

28175

WARNING

Compartment access is restricted.
Contact with components under any cover may result in serious injury.

Only trained maintenance personnel should access compartments. Access by operator is only advised when performing Pre-operation Inspection. All compartments must remain closed and secured during operation.

28175 H

28181

WARNING

Fall Hazard
Death or serious injury may result from climbing or riding on boom.

Keep off this surface.

28181 C

31788

DANGER

Explosion / Burn Hazard
Will cause death, burns or blindness due to ignition of explosive gases or contact with corrosive acid.

Keep all open flames and sparks away. Wear personal protective equipment, including face shield, gloves and long sleeve shirt.

READ MANUALS
Read all manuals prior to operation. **DO NOT OPERATE** equipment if you do not understand the information in the manuals. Consult your supervisor, the owner or the manufacturer.

31788

65187

DANGER

Tip-over Hazard
Altering or disabling limit switches can result in machine tip-over. Machine tip-over will result in death or serious injury.

Do not alter or disable limit switch(es).

LSB160 Safety limit switch for 10' or 12'
LSB162 Safety limit switch for 15' or 18'

65187 C

65428

DANGER

Tip-over Hazard
Failure to replace foam-filled tires with tires of same specification will cause death or serious injury.

Tires are critical to machine stability. Do not replace original factory-installed tires with tires of different specification or ply rating.

65428 B

82289

DANGER

Tip-over Hazard
Altering or disabling limit switches can result in machine tip-over. Machine tip-over will result in death or serious injury.

Do not alter or disable limit switch(es).

LSB160 Operator limit switch for boom length at 10'
LSB162 Operator limit switch for boom length at 12'
LSB164 Operator limit switch for boom length at 15'
LSB166 Operator limit switch for boom length at 18'
LSB168 Operator limit switch for boom length at 21'

82289 B

97602

WARNING

Explosion Hazard
Death or serious injury can result from the use of either other high energy starting aids.

Do not use either or other high energy starting aids on machines equipped with glow plugs.

97602 B

114390

DANGER

Electrocution Hazard
Death or injury can result from contacting electric power lines.

Always contact the electric power line owner. The electric power shall be disconnected or the power lines moved or insulated before machine operations begin.

Line Voltage	Required Clearance
0 to 50kV	10 ft. 3.0 m
50 to 100kV	15 ft. 4.6 m
100 to 150kV	20 ft. 6.1 m
150 to 200kV	25 ft. 7.6 m
200 to 300kV	30 ft. 9.1 m
300 to 1000kV	45 ft. 13.7 m

114390 A

114258

DANGER

Burn Hazard
Fuel and fumes can explode and burn.

No smoking. No flame. Stop engine.

114258 A

146423

DANGER

Tip-over Hazard
Altering or disabling limit switches can result in machine tip-over. Machine tip-over will result in death or serious injury.

Do not alter or disable limit switch(es).

LSB160 Operator limit switch for boom length at 10'
LSB162 Safety limit switch for boom length at 12'
LSB164 Operator limit switch for boom length at 15'
LSB166 Operator limit switch for boom length at 18'

146423 B

T114285

WARNING

Fall Hazard / Impact Hazard
Falling and/or contact with bucket after boom collapse can result in death or serious injury.

Install the secondary extend cylinder cover before operating machine. Refer to service manual.

T114285 A

General Safety

82472



82487

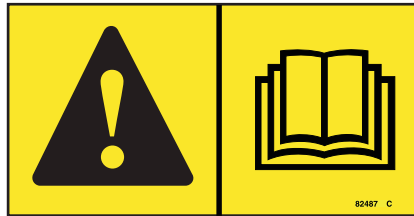

82548

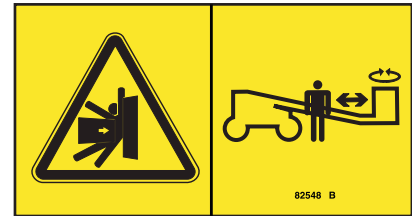

82671

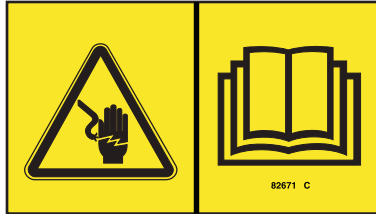

133067

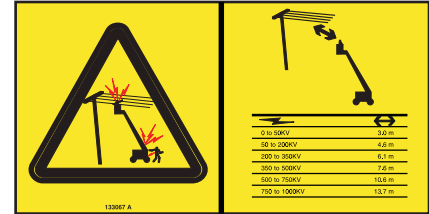

114249

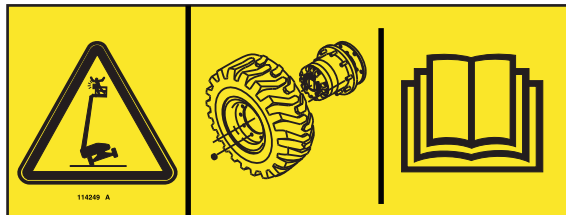

114252



T114286

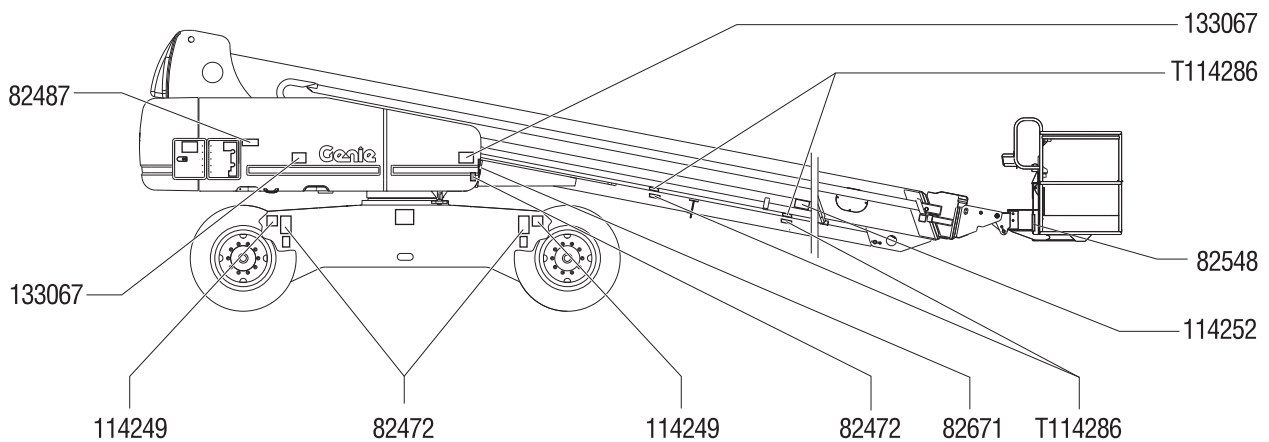
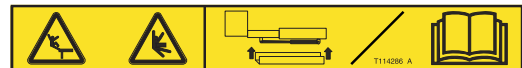

General Safety

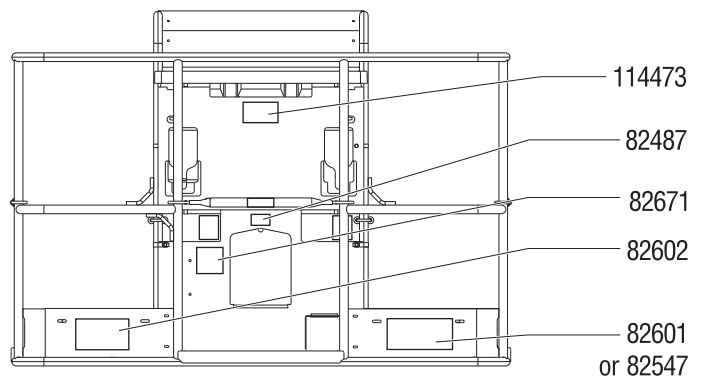
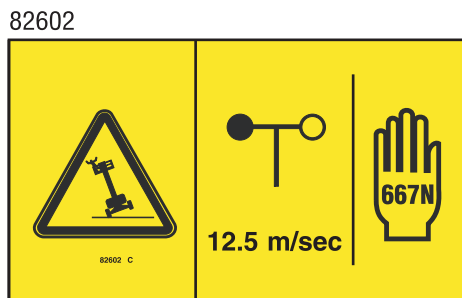
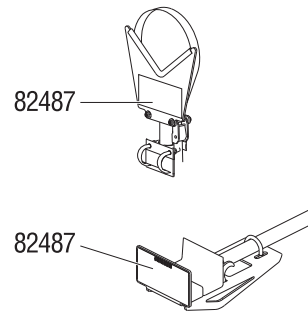

General Safety

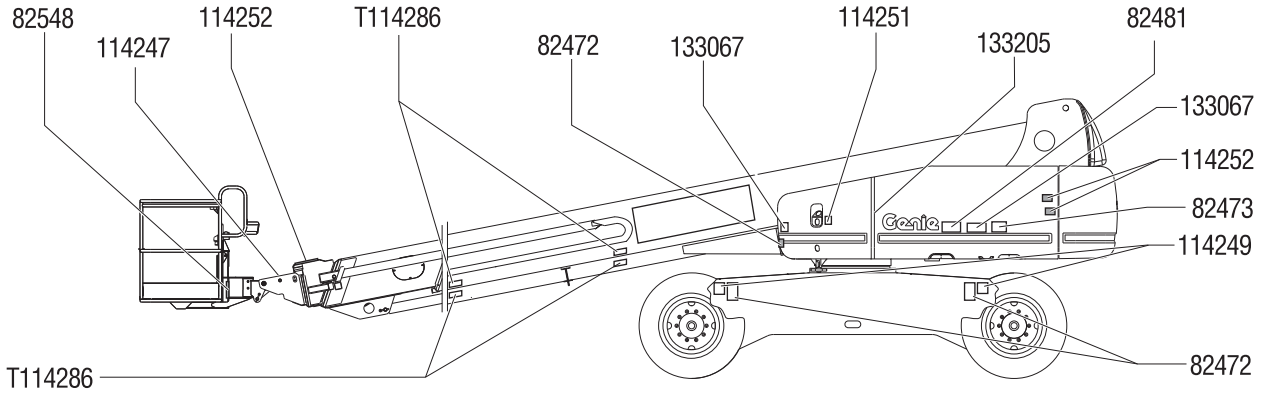

82472



82473



82481



133067



82548

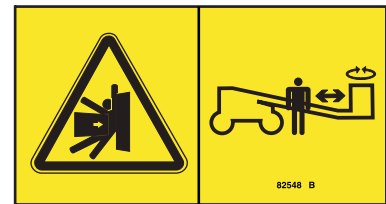

114251



133205



114249

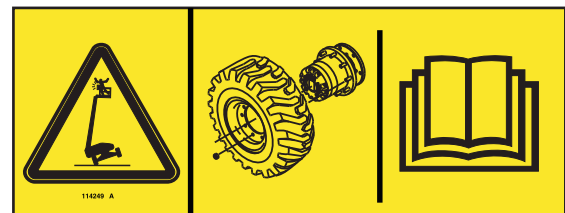

114247



114252



T114286



Personal Safety

Fall Protection

Personal fall protection equipment (PFPE) is required when operating this machine.

Occupants must wear a safety belt or harness in accordance with governmental regulations. Attach the lanyard to the anchor provided in the platform.

Operators must comply with employer, job site and governmental rules regarding the use of personal protective equipment.

All PFPE must comply with applicable governmental regulations, and must be inspected and used in accordance with the PFPE manufacturer's instructions.

Work Area Safety

⚠️ Electrocutation Hazards

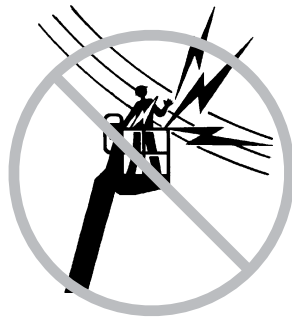

This machine is not electrically insulated and will not provide protection from contact with or proximity to electrical current.

Maintain safe distances from electrical power lines and apparatus in accordance with applicable governmental regulations and the following chart.

Line Voltage	Required Clearance	
0 to 50KV	10 ft	3.0 m
50KV to 200KV	15 ft	4.6 m
200KV to 350KV	20 ft	6.1 m
350KV to 500KV	25 ft	7.6 m
500KV to 750KV	35 ft	10.6 m
750KV to 1000KV	45 ft	13.7 m

Allow for platform movement, electrical line sway or sag and beware of strong or gusty winds.

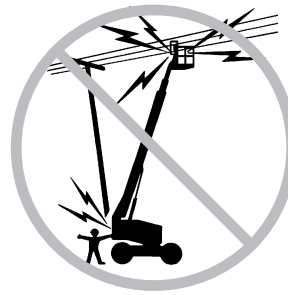

Keep away from the machine if it contacts energized power lines. Personnel on the ground or in the platform must not touch or operate the machine until energized power lines are shut off.

Do not use the machine as a ground for welding unless the machine is equipped with the weld line to platform option and it is properly connected.

⚠️ Tip-over Hazards

Occupants, equipment and materials shall not exceed the maximum platform capacity.

Maximum platform capacity		
S-100	750 lbs	340 kg
S-105	500 lbs	227 kg
S-120	750 lbs	340 kg
S-125	500 lbs	227 kg
Maximum occupants		2

Work Area Safety

The weight of options and accessories, such as pipe cradles, panel cradles and welders, will reduce the rated platform capacity and must be factored into the total platform load. See the decals with the options and accessories.



If using accessories, read, understand and obey the decals and instructions with the accessory.

Do not raise or extend the boom unless the machine is on a firm, level surface.



Do not depend on the tilt alarm as a level indicator. The tilt alarm sounds in the platform only when the machine is on a severe slope.

If the tilt alarm sounds while the boom is lowered: Do not extend, rotate or raise the boom above horizontal. Move the machine to a firm, level surface before raising the platform.

If the tilt alarm sounds while the boom is raised: Use extreme caution. Identify the condition of the boom on the slope as shown below. Follow the steps to lower the boom before moving to a firm, level surface. Do not rotate the boom while lowering.



If the tilt alarm sounds with the platform uphill: First lower the boom, then retract the boom.



If the tilt alarm sounds with the platform downhill: First retract the boom, then lower the boom.

Do not raise the boom when wind speeds may exceed 28 mph / 12.5 m/s. If wind speeds exceed 28 mph / 12.5 m/s when the boom is raised, lower the boom and do not continue to operate the machine.

Work Area Safety



Do not operate the machine in strong or gusty winds. Do not increase the surface area of the platform or the load. Increasing the area exposed to the wind will decrease machine stability.

Use extreme care and slow speeds while driving the machine in the stowed position across uneven terrain, debris, unstable or slippery surfaces and near holes and drop-offs.



Do not drive the machine on or near uneven terrain, unstable surfaces or other hazardous conditions with the boom raised or extended.

Do not use the machine as a crane.

Do not push the machine or other objects with the boom.

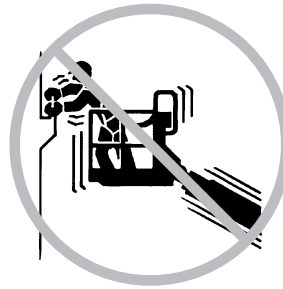

Do not contact adjacent structures with the boom.

Do not tie the boom or platform to adjacent structures.

Do not place loads outside the platform perimeter.

Do not alter or disable the limit switches.

Do not push off or pull toward any object outside of the platform.

Maximum allowable side force - ANSI & CSA	150 lb / 667 N
--	----------------

Maximum allowable manual force - Australia	90 lbs / 400 N
---	----------------

Do not alter or disable machine components that in any way affect safety and stability.

Do not replace items critical to machine stability with items of different weight or specification.

Work Area Safety

Do not modify or alter an aerial work platform without prior written permission from the manufacturer. Mounting attachments for holding tools or other materials onto the platform, toeboards or guard rail system can increase the weight in the platform and the surface area of the platform or the load.



Do not place or attach overhanging loads to any part of this machine.

Do not place ladders or scaffolds in the platform or against any part of this machine.

Do not transport tools and materials unless they are evenly distributed and can be safely handled by person(s) in the platform.



Do not use the machine on a moving or mobile surface or vehicle.

Do not use air-filled tires. These machines are equipped with foam-filled tires. Wheel weight is critical to stability.

Be sure all tires are in good condition, and lug nuts are properly tightened.

Do not use the platform controls to free a platform that is caught, snagged or otherwise prevented from normal motion by an adjacent structure. All personnel must be removed from the platform before attempting to free the platform using the ground controls.

⚠ Operation on Slopes Hazards

Do not drive the machine on a slope that exceeds the maximum uphill, downhill or side slope rating of the machine. Slope rating applies to machines in the stowed position.

Maximum slope rating, stowed position

Platform downhill	40% (22°)
Platform uphill	40% (22°)
Side slope	25% (14°)

Note: Slope rating is subject to ground conditions and adequate traction.

Work Area Safety

⚠ Fall Hazards

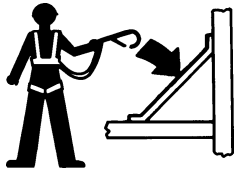

Occupants must wear a safety belt or harness in accordance with governmental regulations. Attach the lanyard to the anchorage point provided in the platform.



Do not sit, stand or climb on the platform guard rails. Maintain a firm footing on the platform floor at all times.



Do not climb down from the platform when raised.

Keep the platform floor clear of debris.

Lower the platform entry mid-rail or close the entry gate before operating.

Do not enter or exit the platform unless the machine is in the stowed position and the platform is at ground level.

⚠ Collision Hazards

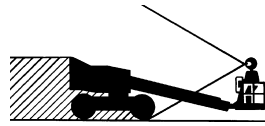

Be aware of limited sight distance and blind spots when driving or operating.



Be aware of the boom position and tailswing when rotating the turntable.

Check the work area for overhead obstructions or other possible hazards.



Be aware of crushing hazards when grasping the platform guard rail.

Operators must comply with employer, job site and governmental rules regarding the use of personal protective equipment.

Observe and use the color-coded direction arrows on the platform controls and drive chassis for drive and steer functions.

Work Area Safety



Do not lower the boom unless the area below is clear of personnel and obstructions.

Limit travel speed according to the condition of the ground surface, congestion, slope, location of personnel, and any other factors which may cause collision.

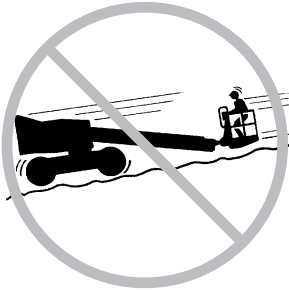

Do not operate a boom in the path of any crane unless the controls of the crane have been locked out and/or precautions have been taken to prevent any potential collision.

No stunt driving or horseplay while operating a machine.

⚠ Bodily Injury Hazard

Do not operate the machine with a hydraulic oil or air leak. An air leak or hydraulic leak can penetrate and/or burn skin.

Always operate the machine in a well-ventilated area to avoid carbon monoxide poisoning.

Do not operate the machine unless the secondary extend cylinder cover is properly installed.

Improper contact with components under any cover will cause serious injury. Only trained maintenance personnel should access compartments. Access by the operator is only advised when performing a pre-operation inspection. All compartments must remain closed and secured during operation.

⚠ Explosion and Fire Hazards

Do not start the engine if you smell or detect liquid petroleum gas (LPG), gasoline, diesel fuel or other explosive substances.

Do not refuel the machine with the engine running.

Refuel the machine and charge the battery only in an open, well-ventilated area away from sparks, flames and lighted tobacco.

Do not operate the machine in hazardous locations or locations where potentially flammable or explosive gases or particles may be present.

Do not spray ether into engines equipped with glow plugs.

Work Area Safety

⚠ Damaged Machine Hazards

Do not use a damaged or malfunctioning machine.

Conduct a thorough pre-operation inspection of the machine and test all functions before each work shift. Immediately tag and remove from service a damaged or malfunctioning machine.

Be sure all maintenance has been performed as specified in this manual and the appropriate Genie service manual.

Be sure all decals are in place and legible.

Be sure the operator's, safety and responsibilities manuals are complete, legible and in the storage container located on the platform.

⚠ Component Damage Hazards

Do not use any battery or charger greater than 12V to jump-start the engine.

Do not use the machine as a ground for welding.

⚠ Battery Safety

Burn Hazards



Batteries contain acid. Always wear protective clothing and eye wear when working with batteries.

Avoid spilling or contacting battery acid. Neutralize battery acid spills with baking soda and water.

Explosion Hazard



Keep sparks, flames and lighted tobacco away from batteries. Batteries emit explosive gas.



The battery tray should remain open during the entire cycle.



Do not contact the battery terminals or the cable clamps with tools that may cause sparks.

⚠ Electrocutation/Burn Hazards

Avoid contact with electrical terminals.

Work Area Safety

⚠ Welder Safety

Read, understand and obey all warnings and instructions provided with the welding power unit.

Do not connect weld leads or cables unless the welding power unit is turned off at the platform controls.

Do not operate unless the weld cables are properly connected and the welder is properly grounded.

The weight of the welder will reduce the rated platform capacity and must be factored into the total platform load. The welder power supply weighs 75 lbs / 34 kg.

Do not operate the welder unless a fire extinguisher is immediately available for instant use, per OSHA regulation 1926.352(d).

⚠ Weld Line to Platform Safety

Read, understand and obey all warnings and instructions provided with the welding power unit.

Do not connect weld leads or cables unless the welding power unit is turned off at the platform controls.

Do not operate unless the weld cables are properly connected.

Connect the positive lead to the twist-lock connector at the turntable and platform.

Clamp the negative lead to the ground post at the turntable and platform.

Work Area Safety

⚠ Pipe Cradle Safety

Read, understand and obey all warnings and instructions provided with the pipe cradles.

Do not exceed the rated platform capacity. The pipe cradle assembly and the weight in the pipe cradles will reduce rated platform capacity and must be factored into total platform load.

The pipe cradle assembly weighs 21 lbs / 9.5 kg.

The maximum capacity of the pipe cradle assembly is 200 lbs / 90.7 kg.

The weight of the pipe cradle assembly and the load in the pipe cradles may limit the maximum number of occupants in platform.

Center the load within the perimeter of the platform.

Secure the load to the platform.

Do not obstruct the entrance or the exit of the platform.

Do not obstruct the ability to operate the platform controls or the red Emergency Stop button.

Do not operate unless you are adequately instructed and are aware of all of the hazards associated with movement of the platform with an overhanging load.

Do not cause a horizontal force or side load to the machine by raising or lowering a fixed or overhanging load.

Electrocution Hazard: Keep pipes away from all energized electrical conductors.

⚠ Panel Cradle Safety

Read, understand and obey all warnings and instructions provided with the panel cradles.

Do not exceed the rated platform capacity. The combined weight of the cradles, panels, occupants, tools and any other equipment must not exceed rated capacity.

The panel cradle assembly weighs 30 lbs / 13.6 kg.

The maximum capacity of the panel cradles is 250 lbs / 113 kg.

The weight of the panel cradles and the load in the panel cradles may limit the maximum number of occupants in platform to one person.

Secure the cradles to the platform. Secure the panel(s) to the platform railing using the straps provided.

Do not operate unless you are adequately instructed and are aware of all hazards associated with lifting panels.

Do not cause a horizontal force or side load to machine by raising or lowering a fixed or overhanging load.

Maximum vertical height of panels: 4 ft / 1.2 m

Maximum wind speed: 15 mph / 6.7 m/sec

Maximum panel area: 32 sq. ft / 3 m²

Work Area Safety

Lockout After Each Use

- 1 Select a safe parking location—firm level surface, clear of obstruction and traffic.
- 2 Retract and lower the boom to the stowed position.
- 3 Rotate the turntable so that the boom is between the wheels at the circle end of the machine.
- 4 Turn the key switch to the off position and remove the key to secure from unauthorized use.
- 5 Chock the wheels.

Legend

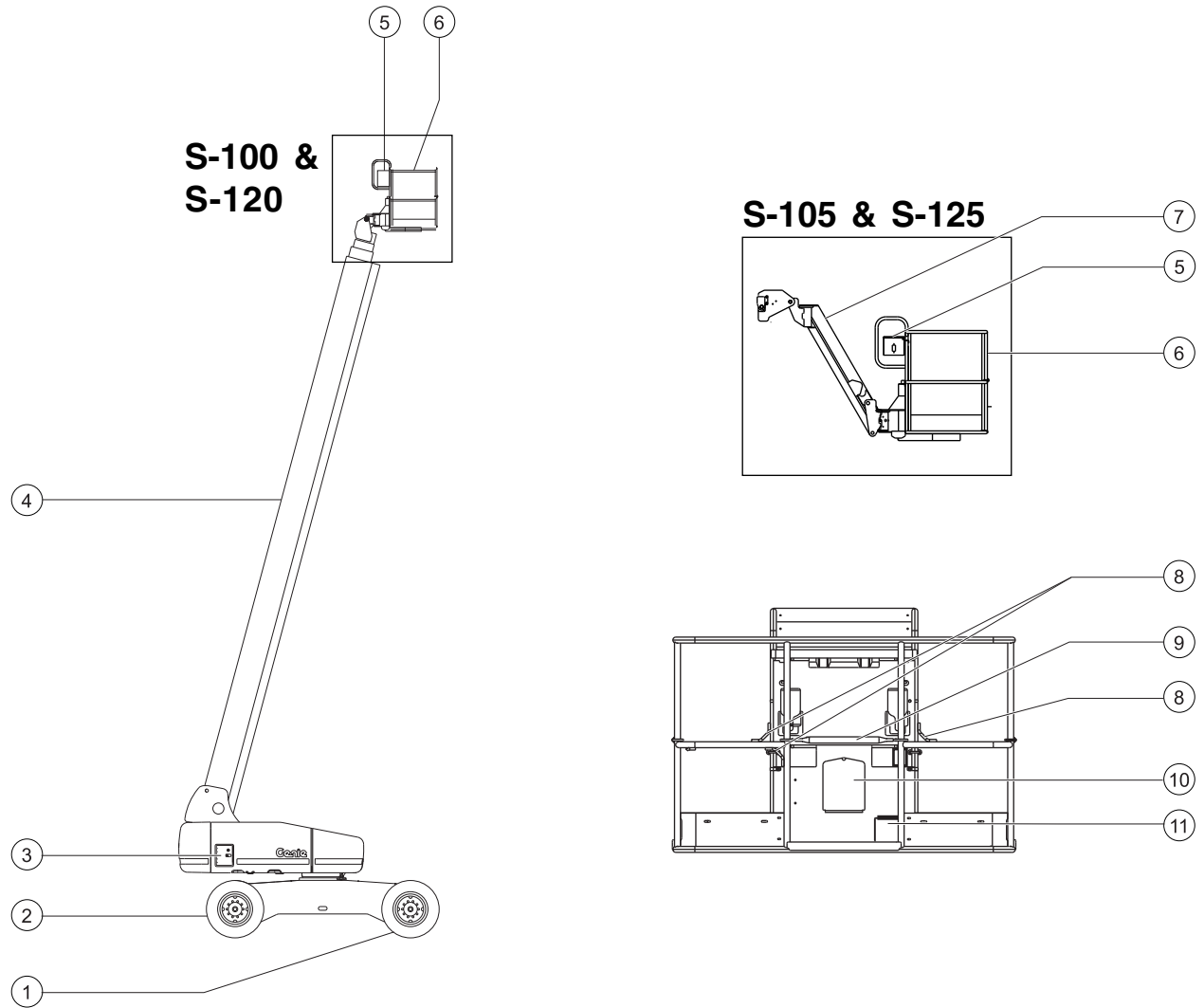

- 1 Circle-end tire (yellow arrow)
- 2 Square-end tire (blue arrow)
- 3 Ground controls
- 4 Boom
- 5 Platform controls
- 6 Platform
- 7 Jib boom (S-105 and S-125)

- 8 Lanyard anchorage point
- 9 Sliding mid-rail
- 10 Manual storage container
- 11 Foot switch

Controls

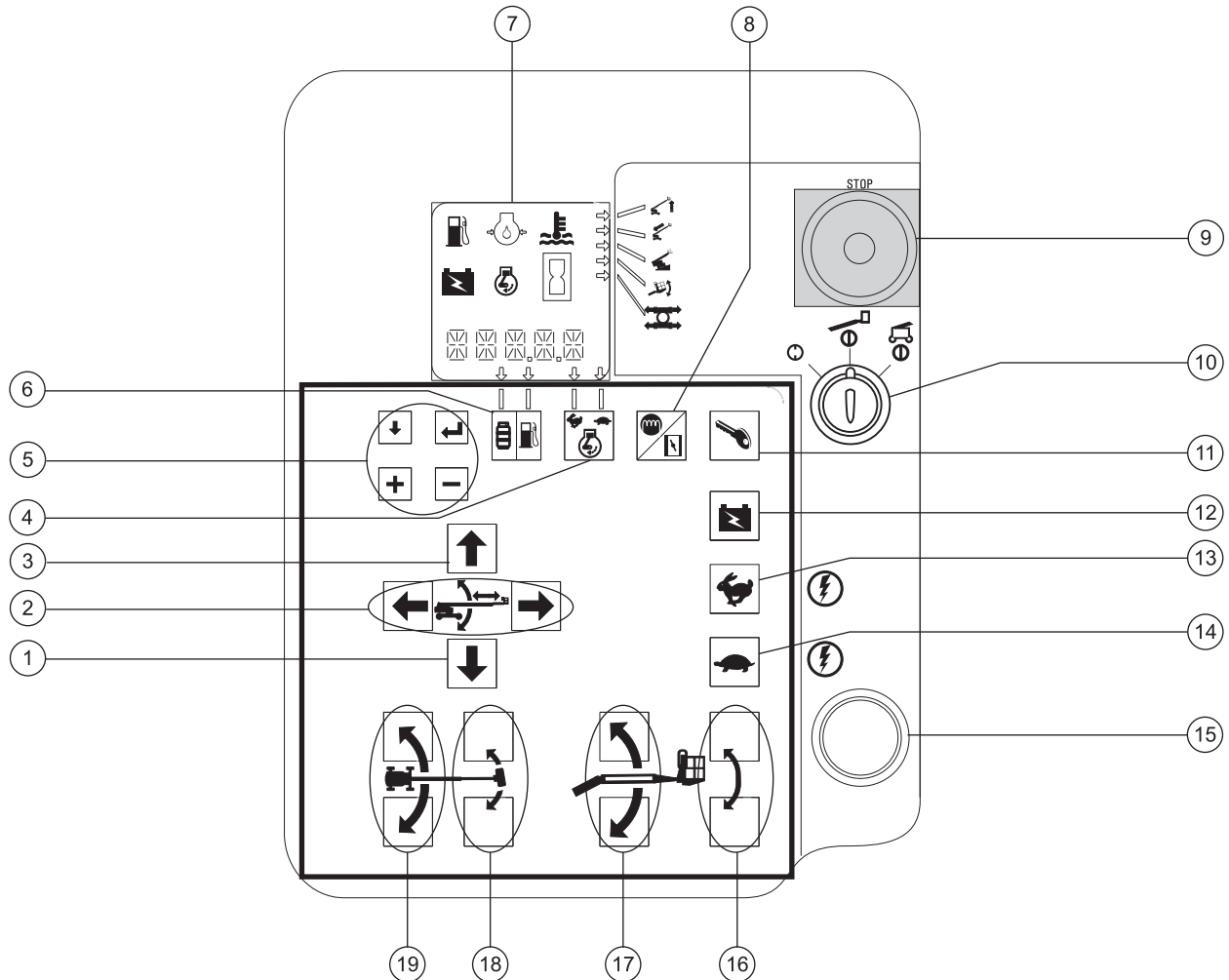

Ground Control Panel

- | | |
|--|---|
| 1 Boom down button | 11 Engine start button |
| 2 Boom extend/retract buttons | 12 Emergency power button |
| 3 Boom up button | 13 High speed function enable button |
| 4 Engine speed select button | 14 Low speed function enable button |
| 5 LCD screen control buttons | 15 Alarm |
| 6 Gasoline/LPG select button | 16 Platform level up/down buttons |
| 7 LCD readout screen | 17 S-105 and S-125 models: Jib boom up/down buttons |
| 8 Diesel models: Glow plug button
Gasoline/LPG models: Choke button | 18 Platform rotate left/right buttons |
| 9 Red Emergency Stop button | 19 Turntable rotate left/right buttons |
| 10 Key switch for off/platform/ground selection | |



Controls

1 Boom down button

Push the boom down button and the boom will lower.

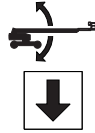

2 Boom extend/retract buttons

Push the boom extend button and the boom will extend.

Push the boom retract button and the boom will retract.

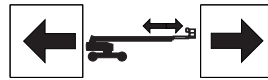

3 Boom up button

Push the boom up button and the boom will raise.

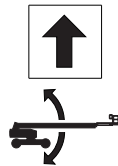

4 Engine speed select button

Push the engine speed select button to select the engine speed. When the arrow above the rabbit is lit, the engine is in high idle speed. When the arrow above the turtle is lit, the engine is in low idle speed.

5 LCD screen control buttons

6 Gasoline/LPG select button

Push the fuel select button to select the engine fuel source. When the arrow above the LPG tank is lit, the engine will run on LPG. When the arrow above the gas tank is lit, the engine will run on gasoline.

7 LCD readout screen



a low fuel indicator

b engine oil pressure indicator

c water temperature indicator

d emergency power indicator

e high engine rpm indicator

f hour meter

8 Diesel models: Glow plug button

Gasoline/LPG models: Choke button

Push the glow plug button and hold for 3 to 5 seconds.

9 Red Emergency Stop button

Push in red Emergency Stop button to the off position to stop all functions and turn the engine off. Pull out the red Emergency Stop button to the on position to operate the machine.

10 Key switch for off/ground/platform selection

Turn the key switch to the off position and the machine will be off. Turn the key switch to the ground position and the ground controls will operate. Turn the key switch to the platform position and the platform controls will operate.

Controls

11 Engine start button

Push the engine start button and the engine will start.

12 Emergency power button

Use emergency power if the primary power source (engine) fails. Simultaneously push the emergency power button and activate the desired function.

13 High speed function enable button

Push the high speed function enable switch to enable the functions on the ground control panel to operate at high speed.

14 Low speed function enable button

Push the low speed function enable switch to enable the functions on the ground control panel to operate at low speed.

15 Alarm

16 Platform level up/down buttons

Push the platform level up button and the level of the platform will raise.

Push the platform level down button and the level of the platform will lower.

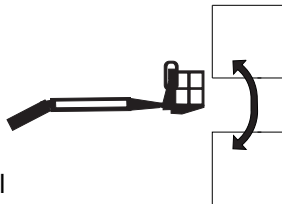

17 S-105 and S-125 models:

Jib boom up/down buttons

Push the jib boom up button and the jib boom will raise.

Push the jib boom down button and the jib boom will lower.

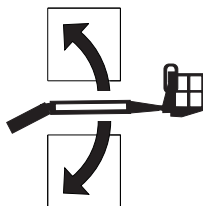

18 Platform rotate left/right buttons

Push the platform rotate left button and the platform will rotate to the left.

Push the platform rotate right button and the platform will rotate to the right.

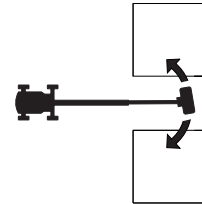

19 Turntable rotate left/right buttons

Push the turntable rotate left button and the turntable will rotate to the left.

Push the turntable rotate right button and the turntable will rotate to the right.

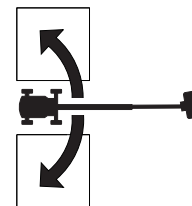

Controls

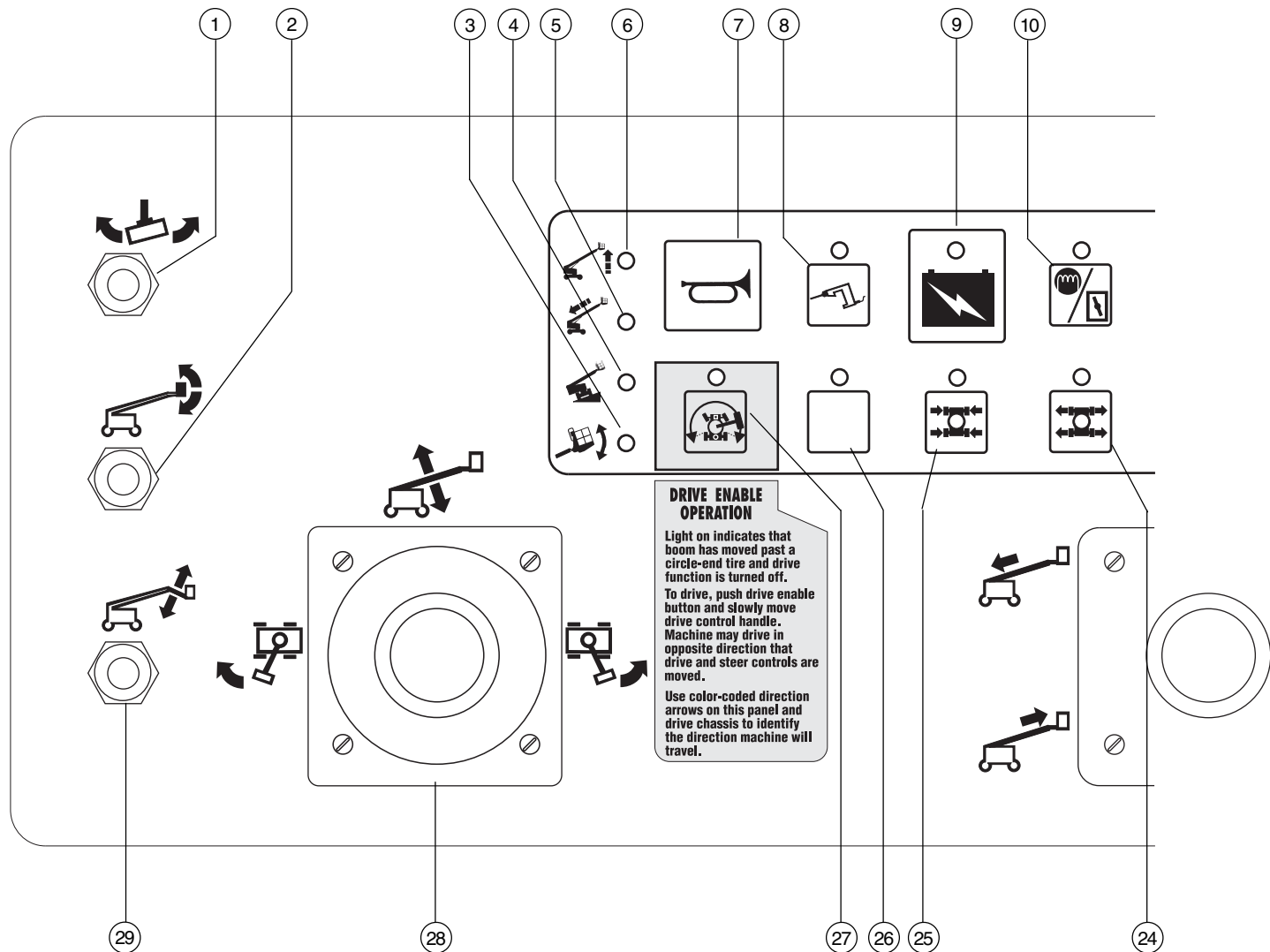

Platform Control Panel

- 1 Platform rotate switch
- 2 Platform level switch
- 3 Platform not level indicator light
- 4 Machine not level indicator light
- 5 Retract boom indicator light
- 6 Raise boom indicator light
- 7 Horn button
- 8 Generator button with indicator light (option)

- 9 Emergency power button with indicator light
- 10 Diesel models: Glow plug button with indicator light
Gasoline/LPG models: Choke button with indicator light
- 11 Engine start button with indicator light

- 12 Engine idle (rpm) select button with indicator lights:
 - Rabbit & Foot Switch: foot switch activated high idle
 - Turtle: low idle
 - Rabbit: high idle
- 13 Gasoline/LPG models: Fuel select button with indicator lights
- 14 Fault indicator light
- 15 Low fuel indicator light
- 16 Check engine indicator light



Controls

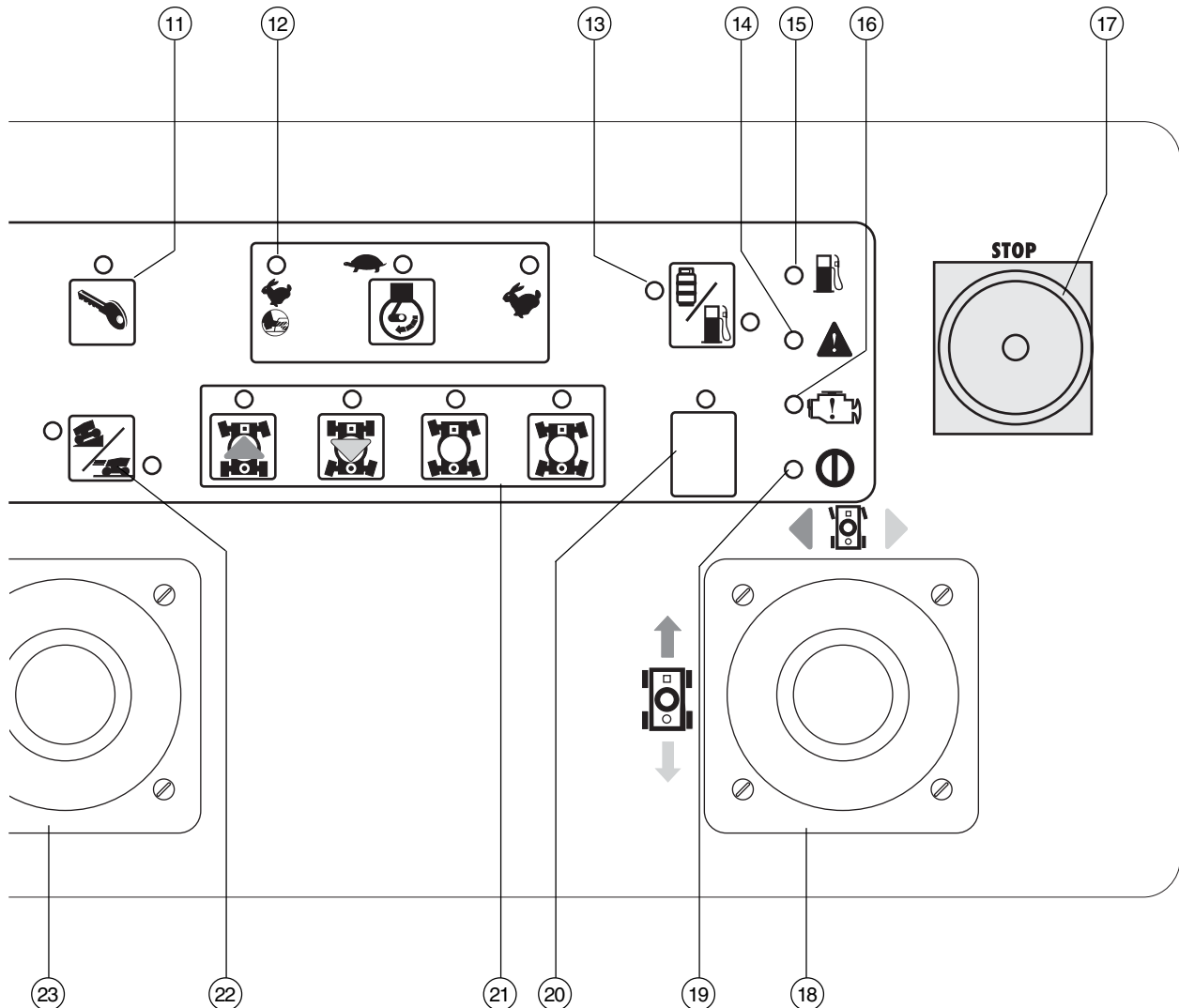

17 Red Emergency Stop button

18 Dual axis proportional control handle for drive and steer functions
OR Proportional control handle for drive function and thumb rocker for steer function

19 Power indicator light

20 Not used

21 Steer mode select buttons with indicator lights

22 Drive select button with indicator lights:
Machine on incline symbol: Low range operation for inclines
Machine on level surface symbol: High range operation for maximum drive speed

23 Single axis proportional control handle for boom extend/retract function

24 Axle extend button with indicator light

25 Axle retract button with indicator light

26 Used for optional equipment

27 Drive enable button with indicator light

28 Dual axis proportional control handle for boom up/down and turntable rotate left/right functions

29 S-105 and S-125 models only: Jib boom up/down toggle switch

Controls

Platform Control Panel

1 Platform rotate switch

Move the platform rotate switch to the right and the platform will rotate to the right. Move the platform rotate switch to the left and the platform will rotate to the left.



2 Platform level switch

Move the platform level switch up and the level of the platform will raise. Move the platform level switch down and the level of the platform will lower.

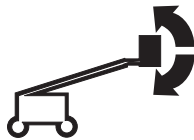

3 Platform not level indicator light

Light is on when the platform is not level. The tilt alarm will be sounding. The Platform Level switch will only work in the direction that will level the platform. Level the platform until the light goes off.

4 Machine not level indicator light

Light is on when the tilt alarm is sounding. Move the machine to level ground.

5 Retract boom indicator light

To continue lowering, retract boom until the indicator light goes out.

6 Raise boom indicator light

To continue extending, raise the boom until the indicator light goes out.

7 Horn button

Push the horn button and the horn will sound. Release the horn button and the horn will stop.

8 Generator button with indicator light (option)

Push the generator button to activate the generator. The light will be on. Push the button again to turn off the light and restore machine functions.

9 Emergency power button with indicator light

Use emergency power if the primary power source (engine) fails. Simultaneously push the emergency power button and step on the foot switch. Activate the desired function. The indicator light will be on when emergency power is being used.

10 Diesel models: Glow plug button with indicator light

Push the glow plug button and hold for 3 to 5 seconds. The glow plug indicator light will be on when the glow plugs are being used.

Gasoline/LPG models: Choke button with indicator light

Push the choke button and hold for 3 to 5 seconds. The choke indicator light will be on when the choke is being used.

11 Engine start button with indicator light

Push the engine start button and the engine will start. The engine start button indicator light will be on when the button is being pushed.

Controls

12 Engine idle (rpm) select button with indicator lights

Push the engine idle select button to choose engine rpm setting. The indicator light next to the current setting will be on.

13 Gasoline/LPG models: Fuel select button with indicator lights

When the indicator light next to the LPG tank is lit, the engine will run on LPG. When the indicator light next to the gas tank is lit, the engine will run on gasoline.

14 Fault indicator light

Light on indicates the machine has one or more faults. Faults are abnormal conditions that exist due to component failure or system misuse. See the appropriate service manual.

15 Low fuel indicator light

Light on indicates the machine is low on fuel.

16 Check engine indicator light

Light on indicates an engine fault.

17 Red Emergency Stop button

Push in red Emergency Stop button to the off position to stop all functions and turn the engine off. Pull out the red Emergency Stop button to the on position to operate the machine.

18 Dual axis proportional control handle for drive and steer functions

OR Proportional control handle for drive function and thumb rocker switch for steer function

Move the control handle in the direction indicated by the blue arrow on the control panel and the machine will drive forward. Move the control handle in the direction indicated by the yellow arrow and the machine will drive backwards. Move the control handle in the direction indicated by the blue triangle and the machine will steer to the left. Move the control handle in the direction indicated by the yellow triangle and the machine will steer to the right.

OR

Move the control handle in the direction indicated by the blue arrow on the control panel and the machine will drive forward. Move the control handle in the direction indicated by the yellow arrow and the machine will drive backwards. Press the left side of the rocker switch and the machine will steer to the left. Press the right side of the rocker switch and the machine will steer to the right.

19 Power indicator light

Light is on when the red Emergency Stop button is pulled out to the on position.

20 Not used

21 Steer mode select buttons with indicator lights

Push the steer mode select button to choose steer mode. The indicator light next to the current steer mode will be on.

Controls

22 Drive select button with indicator lights

Push the drive select button to choose drive setting. The indicator light next to the current setting will be on.

23 Single axis proportional control handle for boom extend/retract function

Move the control handle up and the boom will retract.



Move the control handle down and the boom will extend.



24 Axle extend button with indicator light

Push the axle extend button to extend the axles. The indicator light will flash while the axles are extending and stay on when the axles are fully extended.

25 Axle retract button with indicator light

Push the axle retract button to retract the axles. The indicator light will flash while the axles are retracting and stay on when the axles are fully retracted.

26 Used for optional equipment.

27 Drive enable button with indicator light

Light on indicates that the primary boom has moved past either circle-end wheel and the drive function is turned off. To drive, push the drive enable button and slowly move the drive/steer control handle off center.

28 Dual axis proportional control handle for boom up/down and turntable rotate left/right functions

Move the control handle up and the boom will raise.



Move the control handle down and the boom will lower.



Move the control handle to the left and the turntable will rotate to the left.



Move the control handle to the right and the turntable will rotate to the right.

29 S-105 and S-125 models: Jib boom up/down toggle switch

Move the jib boom switch up and the jib will raise.

Move the jib boom switch down and the jib will lower.

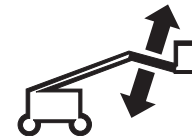

Inspections



Do Not Operate Unless:

- You learn and practice the principles of safe machine operation contained in this operator's manual.
 - 1 Avoid hazardous situations.
 - 2 Always perform a pre-operation inspection.**
 - Know and understand the pre-operation inspection before going on to the next section.**
 - 3 Always perform function tests prior to use.
 - 4 Inspect the workplace.
 - 5 Only use the machine as it was intended.

Pre-operation Inspection Fundamentals

It is the responsibility of the operator to perform a pre-operation inspection and routine maintenance.

The pre-operation inspection is a visual inspection performed by the operator prior to each work shift. The inspection is designed to discover if anything is apparently wrong with a machine before the operator performs the function tests.

The pre-operation inspection also serves to determine if routine maintenance procedures are required. Only routine maintenance items specified in this manual may be performed by the operator.

Refer to the list on the next page and check each of the items.

If damage or any unauthorized variation from factory delivered condition is discovered, the machine must be tagged and removed from service.

Repairs to the machine may only be made by a qualified service technician, according to the manufacturer's specifications. After repairs are completed, the operator must perform a pre-operation inspection again before going on to the function tests.

Scheduled maintenance inspections shall be performed by qualified service technicians, according to the manufacturer's specifications and the requirements listed in the responsibilities manual.

Inspections

Pre-operation Inspection

- Be sure that the operator's, safety and responsibilities manuals are complete, legible and in the storage container located in the platform.
- Be sure that all decals are legible and in place. See Inspections section.
- Check for engine oil leaks and proper oil level. Add oil if needed. See Maintenance section.
- Check for hydraulic oil leaks and proper oil level. Add oil if needed. See Maintenance section.
- Check for engine coolant leaks and proper level of coolant. Add coolant if needed. See Maintenance section.
- Check for battery fluid leaks and proper fluid level. Add distilled water if needed. See Maintenance section.

Check the following components or areas for damage, improperly installed or missing parts and unauthorized modifications:

- Electrical components, wiring and electrical cables
- Hydraulic hoses, fittings, cylinders and manifolds
- Fuel and hydraulic tanks
- Drive and turntable motors and drive hubs

- Boom and axle wear pads
- Tires and wheels
- Engine and related components
- Limit switches and horn
- Alarms and beacons (if equipped)
- Nuts, bolts and other fasteners
- Platform entry mid-rail or gate

Check the entire machine for:

- Cracks in welds or structural components
- Dents or damage to machine
- Excessive rust, corrosion or oxidation
- Be sure that all structural and other critical components are present and all associated fasteners and pins are in place and properly tightened.

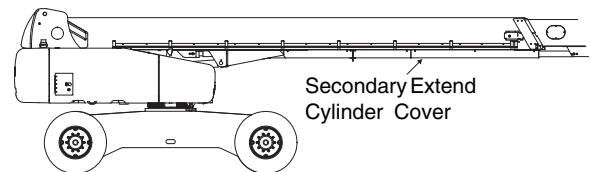

- Be sure the secondary extend cylinder cover is properly installed.
- After you complete your inspection, be sure that all compartment covers are in place and latched.

Inspections



Do Not Operate Unless:

- ☑ You learn and practice the principles of safe machine operation contained in this operator's manual.

- 1 Avoid hazardous situations.
- 2 Always perform a pre-operation inspection.

3 Always perform function tests prior to use.

Know and understand the function tests before going on to the next section.

- 4 Inspect the workplace.
- 5 Only use the machine as it was intended.

Function Test Fundamentals

The function tests are designed to discover any malfunctions before the machine is put into service. The operator must follow the step-by-step instructions to test all machine functions.

A malfunctioning machine must never be used. If malfunctions are discovered, the machine must be tagged and removed from service. Repairs to the machine may only be made by a qualified service technician, according to the manufacturer's specifications.

After repairs are completed, the operator must perform a pre-operation inspection and function tests again before putting the machine into service.

- 1 Select a test area that is firm, level and free of obstruction.

At the Ground Controls

- 2 Turn the key switch to ground control.
- 3 Pull out the red Emergency Stop button to the on position.
- ⦿ Result: The LCD screen will come on and display no error messages. The beacon (if equipped) should flash.

Note: In cold climates, the LCD readout screen will need to warm up before the display appears.

- 4 Start the engine (see Operating Instructions section).

Inspections

Test Emergency Stop

- 5 Push in the red Emergency Stop button to the off position.
- ⦿ Result: The engine should turn off and no functions should operate.
- 6 Pull out the red Emergency Stop button to the on position and restart the engine.

Test the Hydraulic Oil Return Filter

- 7 Press the engine idle speed select button until the indicator light next to high idle (rabbit symbol) is on.
- 8 Lift the tank side turntable cover to locate and check the hydraulic filter condition indicator.
- ⦿ Result: The indicator should be in the green area.
- 9 Close and secure the tank side turntable cover.
- 10 Press the engine idle speed select button until the indicator light next to low idle (turtle symbol) is on.

Test the Extendable Axles

Note: Start this test with the axles retracted.

- 11 At the ground controls, push and hold a function enable/speed select button and push the boom up button.



- ⦿ Result: The boom should raise to 10° above horizontal and then stop. The boom should not raise above the limit switch unless both axles are extended.

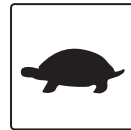

- 12 Push and hold a function enable/speed select button and push the boom down button.

- ⦿ Result: The boom should lower and return to the stowed position.

- 13 Push and hold a function enable/speed select button and press the boom extend button.

- ⦿ Result: The boom should not extend.

- 14 Turn the key switch to platform control. At the platform controls, step on the foot switch and move the drive control handle in the forward direction and push the extend axle button.



- ⦿ Result: The machine should drive and the axles should extend. The indicator light will flash while the axles are moving and stay on when the axles are fully extended.

Note: The extend axle function will only work while the machine is moving.

Inspections

15 Return to the ground controls. Turn the key switch to ground control. Push and hold a function enable/speed select button and push the boom up button and then the boom down button.

- ⦿ Result: The boom should raise and lower normally.

16 At the ground controls, push and hold a function enable/speed select button and push the boom extend button and the boom retract button.

- ⦿ Result: The boom should extend and retract normally.

Test the Machine Functions

17 Do not press and hold a function enable/speed select button. Attempt to activate each boom and platform function button.

- ⦿ Result: No boom and platform functions should operate.

18 Press and hold a function enable/speed select button and activate each boom and platform function button.

- ⦿ Result: All boom and platform functions should operate through a full cycle. The descent alarm (if equipped) should sound while the boom is lowering.

Test Emergency Controls

19 Turn the key switch to ground control and shut the engine off.

20 Pull out the red Emergency Stop button to the on position.

21 Simultaneously push and hold the emergency power button and push each boom function button or activate each boom function toggle switch.



Note: To conserve battery power, test each function through a partial cycle.

- ⦿ Result: All boom functions should operate.

Test the Tilt Sensor

22 Push one of the LCD screen buttons until TURNTABLE LEVEL SENSOR X-DIRECTION appears.



- ⦿ Result: The LCD screen should display the angle in degrees.

23 Push one of the LCD screen buttons until TURNTABLE LEVEL SENSOR Y-DIRECTION appears.

- ⦿ Result: The LCD screen should display the angle in degrees.

24 Push one of the LCD screen buttons until PLATFORM LEVEL SENSOR DEGREES appears.

- ⦿ Result: The LCD screen should display the angle in degrees.

Inspections

Test the Operating Envelope

25 Simultaneously push and then release the LCD screen buttons shown to activate status mode.



26 Push one of the LCD screen buttons shown until BOOM ANGLE is displayed.



27 Raise the boom and observe the LCD screen.

- ⦿ Result: The LCD screen should display:
 - < 10
 - >= 10
 - >= 53
 - > 68

28 Push one of the LCD screen buttons shown until BOOM LENGTH is displayed.



29 Extend the boom and observe the LCD screen.

- ⦿ Result: The LCD screen should display:
 - at 0
 - > 0
 - > 75
 - = 100
 - > 100

30 Retract the boom.

At the Platform Controls

Test Emergency Stop

31 Turn the key switch to platform control.

32 Push in the platform red Emergency Stop button to the off position.

- ⦿ Result: The engine should turn off and no functions should operate.

33 Pull out the red Emergency Stop button and restart the engine.

Test the Horn

34 Push the horn button.

- ⦿ Result: The horn should sound.

Test the Tilt Sensor Alarm

35 Push a button, such as the engine RPM button or the fuel select button.

- ⦿ Result: The alarm should sound at the platform controls.

Inspections

Test the Foot Switch

- 36 Push in the platform red Emergency Stop button to the off position.
 - 37 Pull out the red Emergency Stop button to the on position but do not start the engine.
 - 38 Press down the foot switch and attempt to start the engine by pushing the engine start button.
- ⊙ Result: The engine should not start.
- 39 Do not press down the foot switch and restart the engine.
 - 40 Do not press down the foot switch and test each machine function.
- ⊙ Result: No machine functions should operate.

Test Machine Functions

- 41 Press down the foot switch.
 - 42 Activate each machine function control handle, toggle switch or button.
- ⊙ Result: All functions should operate through a full cycle.

Test the Steering

- 43 Push the steer mode select button for square-end (blue arrow) steer.

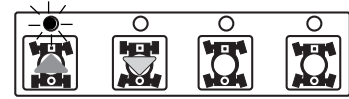

- 44 Press down the foot switch.
 - 45 Slowly move the drive/steer control handle in the direction indicated by the blue triangle on the control panel OR press the thumb rocker switch in the direction indicated by the blue triangle.
- ⊙ Result: The square-end wheels should turn in the direction that the blue triangles point on the drive chassis.

- 46 Push the steer mode select button for circle-end (yellow arrow) steer.

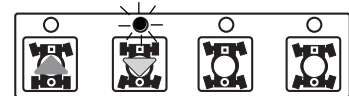

- 47 Press down the foot switch.
 - 48 Slowly move the drive/steer control handle in the direction indicated by the yellow triangle on the control panel OR press the thumb rocker switch in the direction indicated by the yellow triangle.
- ⊙ Result: The circle-end wheels should turn in the direction that the yellow triangles point on the drive chassis.

- 49 Push the steer mode select button for crab steer.

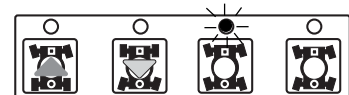

- 50 Press down the foot switch.
 - 51 Slowly move the drive/steer control handle in the direction indicated by the blue triangle on the control panel OR press the thumb rocker switch in the direction indicated by the blue triangle.
- ⊙ Result: All wheels should turn in the direction that the blue triangles point on the drive chassis.

Inspections

- 52 Push the steer mode select button for coordinated steer.

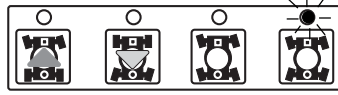

- 53 Press down the foot switch.
- 54 Slowly move the drive/steer control handle in the direction indicated by the blue triangle on the control panel OR press the thumb rocker switch in the direction indicated by the blue triangle.
- ⊙ Result: The square-end wheels should turn in the direction that the blue triangles point on the drive chassis. The circle-end wheels should turn in the direction that the yellow triangles point on the drive chassis.

Test Drive and Braking

- 55 Press down the foot switch.
- 56 Slowly move the drive/steer control handle in the direction indicated by the blue arrow on the control panel until the machine begins to move, then return the handle to the center position.
- ⊙ Result: The machine should move in the direction that the blue arrow points on the drive chassis, then come to an abrupt stop.
- 57 Slowly move the drive/steer control handle in the direction indicated by the yellow arrow on the control panel until the machine begins to move, then return the handle to the center position.
- ⊙ Result: The machine should move in the direction that the yellow arrow points on the drive chassis, then come to an abrupt stop.

Note: The brakes must be able to hold the machine on any slope it is able to climb.

Inspections

Test the Drive Enable System

- 58 Press down the foot switch and lower the boom to the stowed position.
- 59 Rotate the turntable until the boom moves past one of the circle-end tires.

- ⦿ Result: The drive enable indicator light should come on while the boom is anywhere in the range shown.

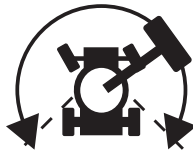

- 60 Move the drive/steer control handle off center.

- ⦿ Result: No drive function should operate.

- 61 Push the drive enable button and slowly move the drive/steer control handle off center.

- ⦿ Result: The drive function should operate.

Note: When the drive enable system is in use, the machine may drive in the opposite direction that the drive and steer control handle is moved.

Use the color-coded direction arrows on the platform controls and the drive chassis to identify the direction of travel.

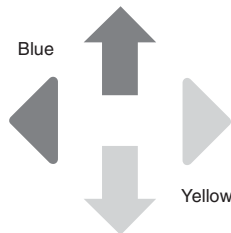

If the drive/steer control handle is not moved within two seconds of pushing the drive enable button, the drive function will not operate.

Test Limited Drive Speed

- 62 Press down the foot switch.
- 63 Raise the boom to 10° above horizontal.
- 64 Slowly move the drive control handle to the full drive position.

- ⦿ Result: The maximum achievable drive speed with the boom raised should not exceed 1 foot / 30 cm per second.

Note: The machine will travel 40 feet / 12.2 m in 40 seconds.

- 65 Lower the boom to the stowed position.

- 66 Extend the boom 4 feet / 1.2 m.

- 67 Slowly move the drive control handle to the full drive position.

- ⦿ Result: The maximum achievable drive speed with the boom extended should not exceed 1 foot / 30 cm per second.

Note: The machine will travel 40 feet / 12.2 m in 40 seconds.

If the drive speed with the boom raised or extended exceeds 1 foot / 30 cm per second, immediately tag and remove the machine from service.

- 68 Raise the boom to horizontal. Extend the boom as far as it will go.

- 69 Slowly move the drive control handle to the full drive position.

- ⦿ Result: The maximum achievable drive speed with the boom fully extended should not exceed 0.6 feet / 18 cm per second.

Note: The machine will travel 40 feet / 12.2 meters in 70 seconds.

Inspections

Test Emergency Controls

70 Shut off the engine.

71 Pull out the red Emergency Stop button to the on position.

72 Press down the foot switch.

73 Simultaneously press and hold the emergency power button and activate each function control handle, toggle switch or button.



Note: To conserve battery power, test each function through a partial cycle.

- ⦿ Result: All boom and steer functions should operate.

Inspections



Do Not Operate Unless:

- You learn and practice the principles of safe machine operation contained in this operator's manual.

- 1 Avoid hazardous situations.
- 2 Always perform a pre-operation inspection.
- 3 Always perform function tests prior to use.

4 Inspect the workplace.

Know and understand the workplace inspection before going on to the next section.

- 5 Only use the machine as it was intended.

Workplace Inspection

Be aware of and avoid the following hazardous situations:

- drop-offs or holes
- bumps, floor obstructions or debris
- sloped surfaces
- unstable or slippery surfaces
- overhead obstructions and high voltage conductors
- hazardous locations
- inadequate surface support to withstand all load forces imposed by the machine
- wind and weather conditions
- the presence of unauthorized personnel
- other possible unsafe conditions

Fundamentals

The workplace inspection helps the operator determine if the workplace is suitable for safe machine operation. It should be performed by the operator prior to moving the machine to the workplace.

It is the operator's responsibility to read and remember the workplace hazards, then watch for and avoid them while moving, setting up and operating the machine.

Inspections

Inspection for Decals with Words

Determine whether the decals on your machine have words or symbols. Use the appropriate inspection to verify that all decals are legible and in place.

Part No.	Description	Quantity
25994	Notice - Component Damage Hazard	1
27204	Arrow - Blue	1
27205	Arrow - Yellow	1
27206	Triangle - Blue	4
27207	Triangle - Yellow	4
28159	Label - Diesel Only	1
28161	Warning - Crushing Hazard	6
28165	Instructions - Foot Switch Operation	1
28174	Label - Power to Platform, 230V	2
28175	Warning - Compartment Access	1
28176	Label - Manual Missing	1
28177	Warning - Crushing Hazard Platform	2
28181	Warning - No Step or Ride	1
28235	Label - Power to Platform, 115V	2
28236	Warning - Read The Manual	1
30080	Instructions - Max. Capacity, 500 lbs/227 kg, S-105 and S-125	1
31788	Danger - Battery Safety	1
38149	Label - Patents	1
40434	Label - Lanyard Anchorage Point	3
43594	Instructions - Max. Capacity, 750 lbs/340 kg, S-100 and S-120	1
44981	Label - Air Line to Platform (option)	2
44986	Instructions - Max. Manual Force, 90 lbs/400 N (AUS)	1

Part No.	Description	Quantity
52865	Warning - Annual Inspection, U.S. Only	1
61227	Ground Control Panel	1
65182	Platform Control Panel	1
65187	Danger - Do Not Alter or Disable Limit Switches	1
65264	Cosmetic - Genie S-125	1
65265	Cosmetic - S-125	1
65266	Cosmetic - 4 x 4	1
65267	Cosmetic - Genie S-120	1
65268	Cosmetic - S-120	1
65273	Label - Tire Specifications, S-120 and S-125	4
65278	Label - No Step	4
65428	Danger - Tip-over Hazard, Tires	4
72119	Label - Range of Motion, S-120 and S-125	1
72131	Label - Cylinder Cover	4
72147	Cosmetic - Genie S-100	1
72148	Cosmetic - Genie S-105	1
72149	Cosmetic - S-100	1
72150	Cosmetic - S-105	1
72151	Label - Tire Specifications, S-100 and S-105	4
72152	Label - Range of Motion, S-100 and S-105	1

This inspection continues on the next page.

Inspections

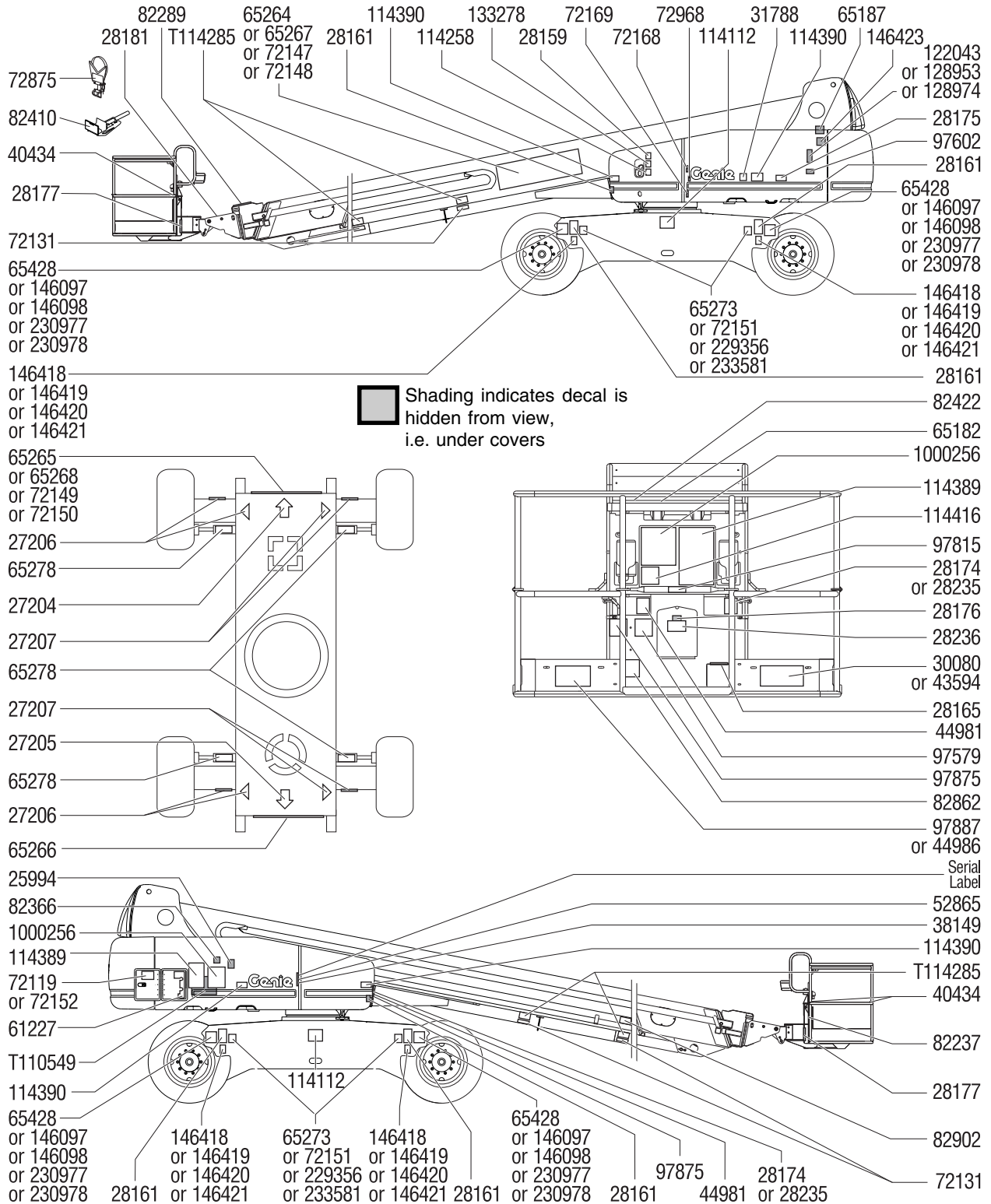

Inspections

Inspection for Decals with Words

Determine whether the decals on your machine have words or symbols. Use the appropriate inspection to verify that all decals are legible and in place.

This inspection is a continuation from the previous page.

Part No.	Description	Quantity
72168	Label - Starter Battery	1
72169	Label - Battery Controls	1
72875	Warning - Pipe Cradle (option)	2
72968	Label - 25 amp Circuit Breaker	1
82237	Danger - High Voltage, Welder (option)	2
82289	Danger - Tip-over Hazard - Do not alter limit switch	1
82366	Label - Chevron Rando	1
82410	Warning - Panel Cradle (option)	2
82422	Label - Work Lights or Driving Lights (option)	1
82862	Danger - Fire Extinguisher, Welder (option)	1
82902	Danger - Tip-over Hazard - Do not alter limit switch	1
97579	Danger - Tip-Over, Welder (option)	1
97602	Warning - Explosion Hazard	1
97815	Label - Mid-rail	1
97875	Warning - Weld Line to Platform (option)	2
97887	Instructions - Max. Side Force, 150 lbs/667 N (ANSI & CSA)	1
114112	Label - Transport Diagram	2
114258	Danger - Explosion Hazard	1
114389	Danger - General Safety Rules	2
114390	Danger - Electrocution Hazard	4

Part No.	Description	Quantity
114416	Danger - Tip-over Hazard, Tilt Alarm	1
122043	Instructions - Engine Specs, Cummins	1
128953	Instructions - Engine Specs, Deutz	1
128974	Instructions - Engine Specs, Perkins	1
133278	Label - Ultra Low or Low Sulfur, US Only	1
146097	Danger- Tire Specifications, Solid Rubber S-100 and S-105	4
146098	Danger- Tire Specifications, Solid Rubber S-120 and S-125	4
146418	Label - Wheel Load, S-100	4
146419	Label - Wheel Load, S-105	4
146420	Label - Wheel Load, S-120	4
146421	Label - Wheel Load, S-125	4
146423	Danger - Do Not Alter or Disable Limit Switches	1
229356	Danger - Tip-over Hazard, Low Profile, S-120 and S-125	4
230977	Danger- Tire Specifications, Solid Rubber S-120 and S-125	4
230978	Danger- Tire Specifications, Solid Rubber S-100 and S-105	4
233581	Danger - Tip-over Hazard, Low Profile, S-100 and S-105	4
1000256	Instructions - Operating Instructions	2
T110549	Label - Fault Code Chart	1
T114285	Warning - Install Cover/Read the Manual	4

Inspections

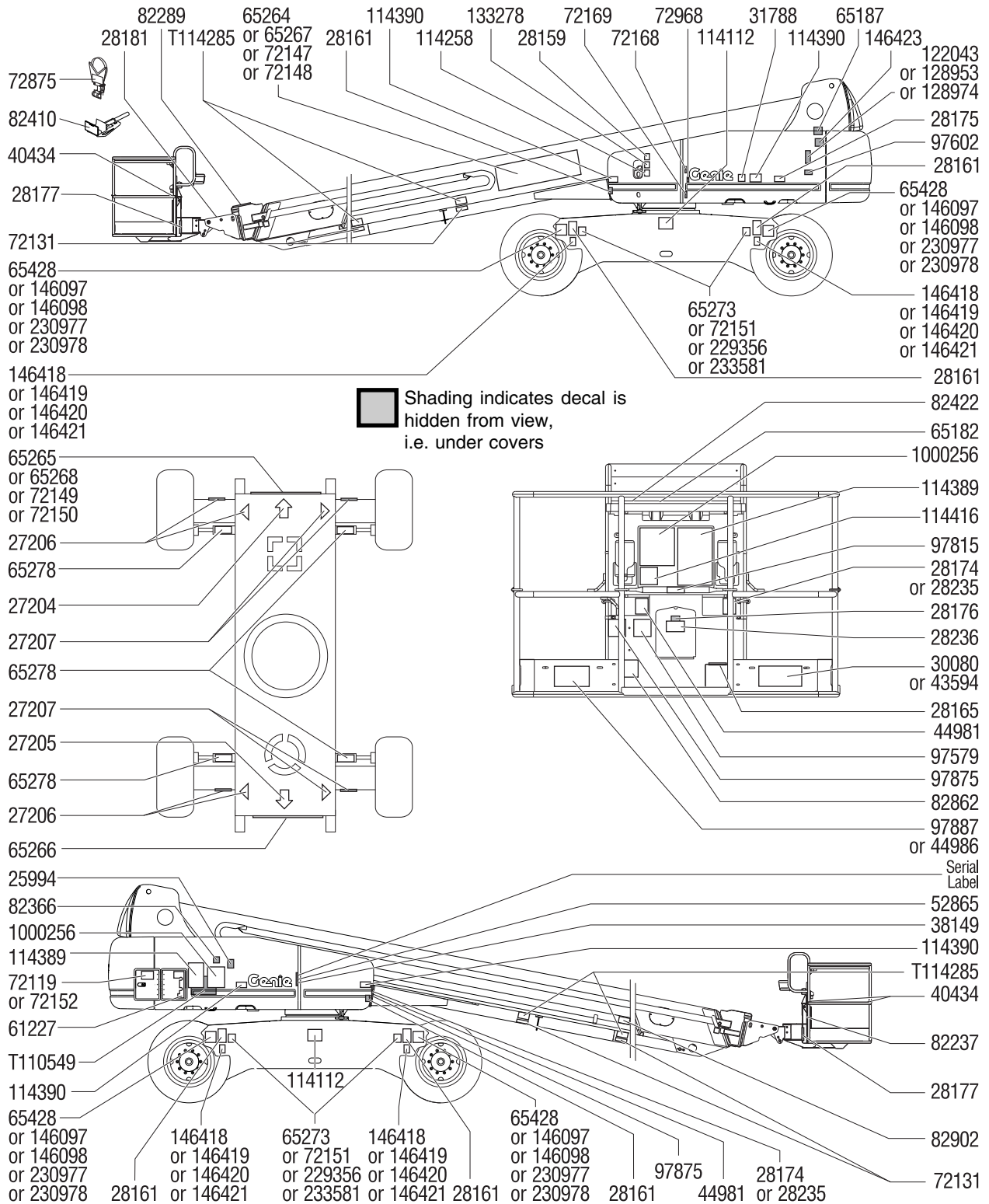

Inspections

Inspection for Decals with Symbols

Determine whether the decals on your machine have words or symbols. Use the appropriate inspection to verify that all decals are legible and in place.

Part No.	Description	Quantity
27204	Arrow - Blue	1
27205	Arrow - Yellow	1
27206	Triangle - Blue	4
27207	Triangle - Yellow	4
28159	Label - Diesel	1
28174	Label - Power to Platform, 230V	2
28235	Label - Power to Platform, 115V	2
40434	Label - Lanyard Anchorage Point	3
44981	Label - Air Line to Platform (option)	2
61227	Ground Control Panel	1
65182	Platform Control Panel	1
65264	Cosmetic - Genie S-125	1
65265	Cosmetic - S-125	1
65266	Cosmetic - 4 x 4	1
65267	Cosmetic - Genie S-120	1
65268	Cosmetic - S-120	1
65278	Label - No Step	4
72119	Label - Range of Motion, S-120 and S-125	1

Part No.	Description	Quantity
72147	Cosmetic - Genie S-100	1
72148	Cosmetic - Genie S-105	1
72149	Cosmetic - S-100	1
72150	Cosmetic - S-105	1
72152	Label - Range of Motion, S-100 and S-105	1
82422	Label - Work Lights or Driving Lights (option)	1
82472	Label - Crushing Hazard	6
82473	Label - Compartment Access	1
82481	Label - Battery Safety	1
82487	Label - Read the Manual	2
82487	Label - Read the Manual, Panel Cradle (option)	2
82487	Label - Read the Manual, Pipe Cradle (option)	2
82547	Label - Maximum Capacity, 340 kg, S-100/S-120	1
82548	Label - Crushing Hazard, Platform	2
82601	Label - Maximum Capacity, 227 kg, S-105 and S-125	1

This inspection continues on the next page.

Inspections

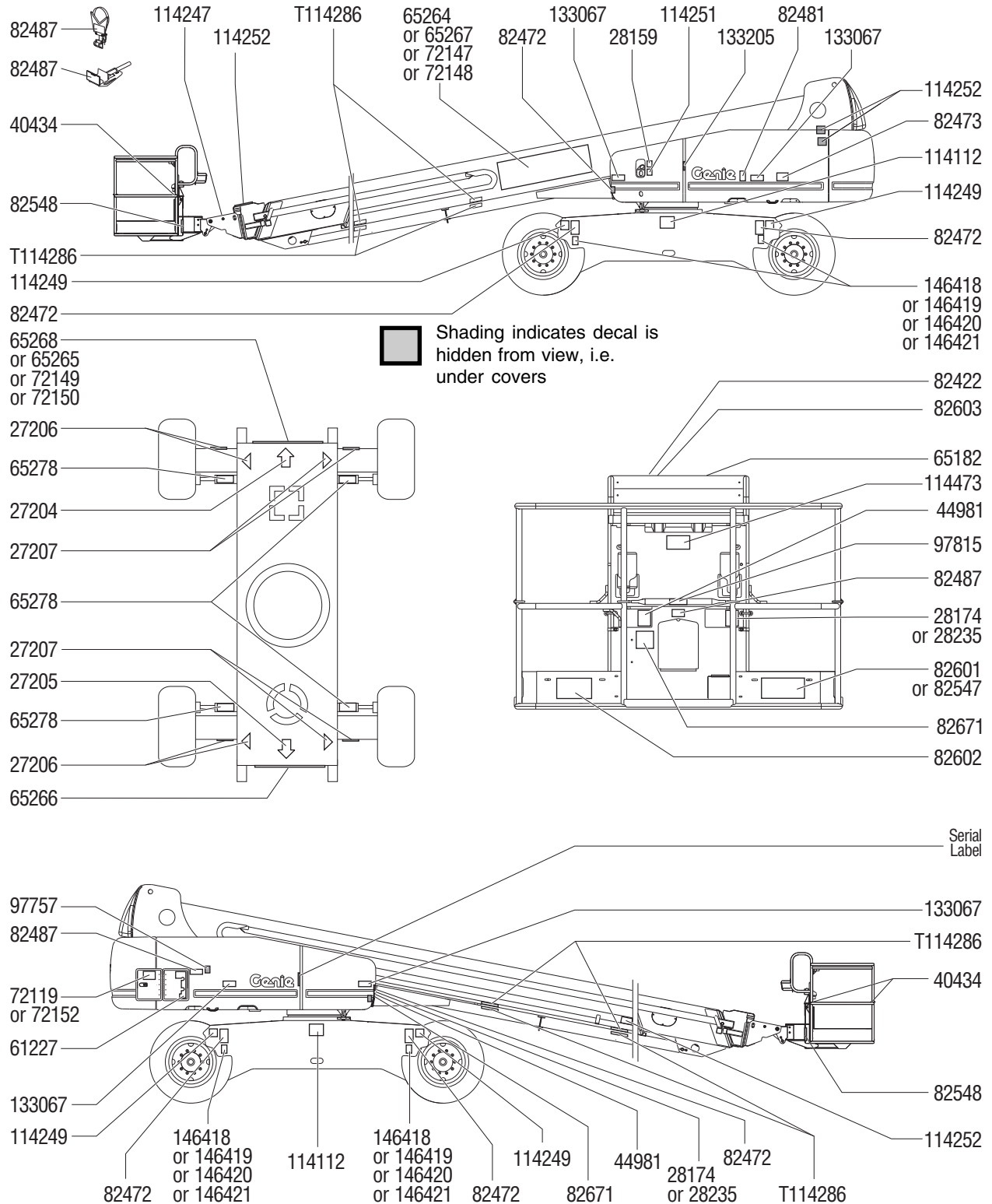

Inspections

Inspection for Decals with Symbols

Determine whether the decals on your machine have words or symbols. Use the appropriate inspection to verify that all decals are legible and in place.

This inspection is a continuation from the previous page.

Part No.	Description	Quantity
82602	Label - Max Side Force, 667 N	1
82603	Label - Drive Enable Patch	1
82671	Label - Weld Line to Platform (option)	2
97757	Label - Hydraulic Oil Level	1
97815	Label - Lower Mid-rail	1
114112	Label - Transport Diagram	2
114247	Label - No Step or Ride	1
114249	Label - Tip-Over Hazard, Tires	4
114251	Label - Explosion Hazard	1
114252	Label - Tip-Over Hazard, Limit Switch	4
114473	Label - Tip-Over Hazard, Tilt Alarm	1
133067	Label - Electrocution Hazard	4
133205	Label - Electrocution Hazard, Battery	1
146418	Label - Wheel Load, S-100	4
146419	Label - Wheel Load, S-105	4
146420	Label - Wheel Load, S-120	4
146421	Label - Wheel Load, S-125	4
T114286	Label - Install Cover/Read the Manual	8

Inspections

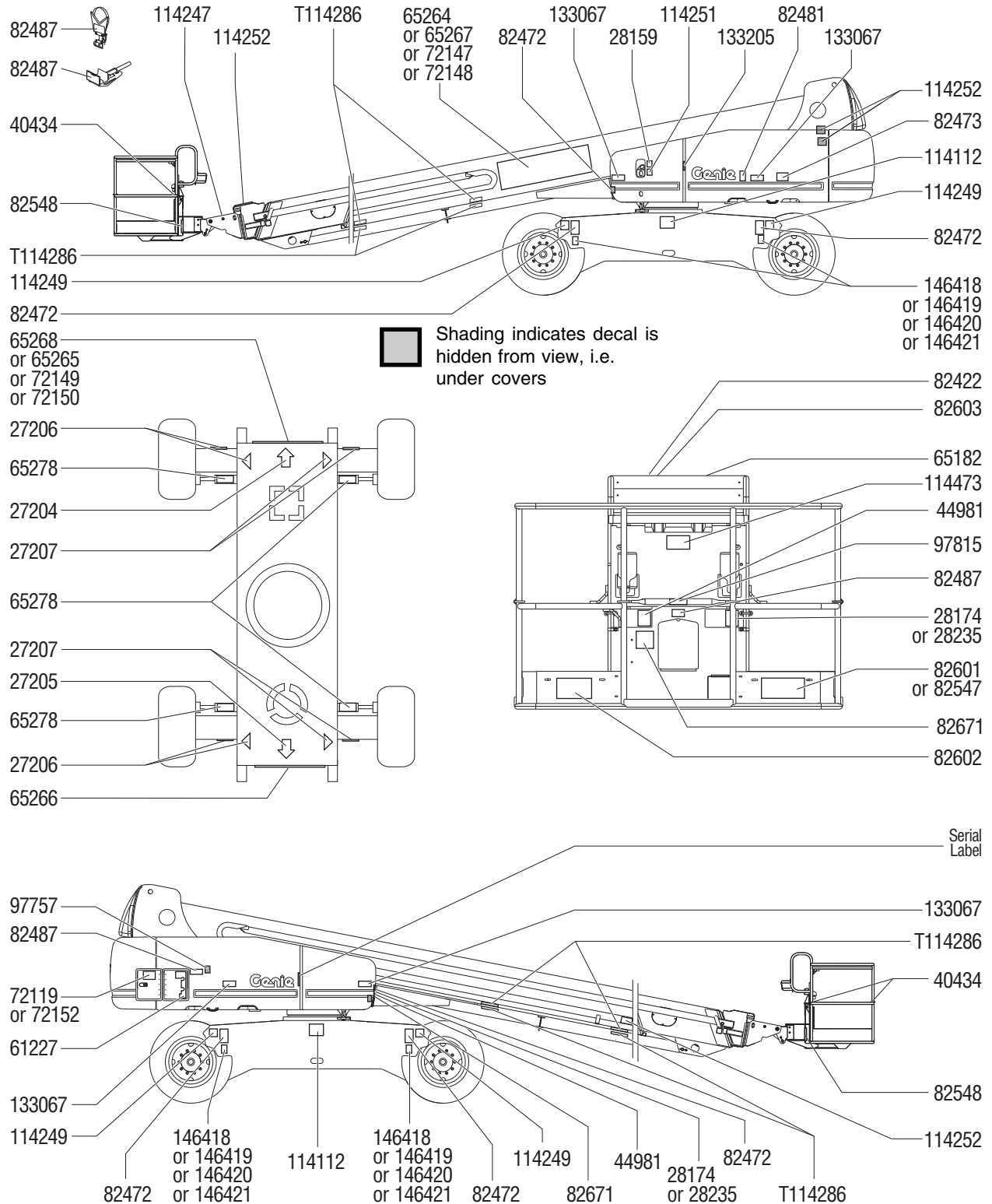

Operating Instructions



Do Not Operate Unless:

- You learn and practice the principles of safe machine operation contained in this operator's manual.
 - 1 Avoid hazardous situations.
 - 2 Always perform a pre-operation inspection.
 - 3 Always perform function tests prior to use.
 - 4 Inspect the workplace.
 - 5 Only use the machine as it was intended.**

Fundamentals

The Operating Instructions section provides instructions for each aspect of machine operation. It is the operator's responsibility to follow all the safety rules and instructions in the operator's, safety and responsibilities manuals.

Using the machine for anything other than lifting personnel, along with their tools and materials, to an aerial work site is unsafe and dangerous.

Only trained and authorized personnel should be permitted to operate a machine. If more than one operator is expected to use a machine at different times in the same work shift, they must all be qualified operators and are all expected to follow all safety rules and instructions in the operator's, safety and responsibilities manuals. That means every new operator should perform a pre-operation inspection, function tests, and a workplace inspection before using the machine.

Operating Instructions

Starting the Engine

- 1 At the ground controls, turn the key switch to the desired position.
- 2 Be sure both ground and platform control red Emergency Stop buttons are pulled out to the on position.

Diesel models

- 3 Press the engine start button.

Note: In cold conditions, 50°F / 10°C and below, push and hold the glow plug button for 10 to 20 seconds before starting the engine.



Gasoline/LPG models

- 3 Choose fuel by pressing the fuel select button.
- 4 Push the engine start button.

Note: In cold conditions, 20°F / -6°C and below, the machine should be started on gasoline and warmed for 2 minutes, then switched to LPG. Warm engines can be started on LPG.

All models

If the engine fails to start or dies, the restart delay will disable the start switch for 3 seconds.

If the engine fails to start after 15 seconds of cranking, determine the cause and repair any malfunction. Wait 60 seconds before trying to start again.

In cold conditions, 20°F / -6°C and below, warm the engine for 5 minutes before operating to prevent hydraulic system damage.

In extreme cold conditions, 0°F / -18°C and below, machines should be equipped with optional cold start kits. Attempting to start the engine when temperatures are below 0°F / -18°C may require the use of a booster battery.

Emergency Stop

Push in either the ground or platform red Emergency Stop button to the off position to stop all functions and turn the engine off.

Repair any function that operates when the red Emergency Stop button is pushed in.

Selecting and operating the ground controls will override the platform red Emergency Stop button.

Emergency Controls

Use emergency power if the primary power source (engine) fails.

- 1 Turn the key switch to ground or platform control.
- 2 Pull out the red Emergency Stop button to the on position.
- 3 Press down the foot switch when operating the emergency controls from the platform.
- 4 Simultaneously hold the emergency power button and activate the desired function.



The drive function will not operate with emergency power.

Operating Instructions

Operation from Ground

- 1 Turn the key switch to ground control.
- 2 Pull out the red Emergency Stop button to the on position.
- 3 Gasoline/LPG models: Choose fuel by pressing the fuel select button.
- 4 Start the engine.

To Position Platform

- 1 Push and hold a function enable/speed select button.
- 2 Push the appropriate function button according to the markings on the control panel.



Drive and steer functions are not available from the ground controls.

Operation from Platform

- 1 Turn the key switch to platform control.
- 2 Pull out both ground and platform red Emergency Stop buttons to the on position.
- 3 Gasoline/LPG models: Choose fuel by pressing the fuel select button.
- 4 Start the engine. Do not press down the foot switch when starting the engine.

To Position Platform

- 1 Press down the foot switch.
- 2 Slowly move the appropriate function control handle or toggle switch or press the appropriate button according to the markings on the control panel.

To Steer

- 1 Press down the foot switch.
- 2 Select the steer mode by pressing a steer mode button. The indicator light next to the current steer mode will be on.

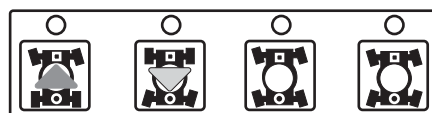

- 3 Slowly move the drive/steer control handle in the direction of the blue or yellow triangle OR press the thumb rocker switch located on top of the drive control handle.

Use the color-coded direction triangles on the platform controls and the drive chassis to identify the direction the wheels will turn.



To Drive

- 1 Press down the foot switch.
- 2 Increase speed: Slowly move the drive/steer control in the blue or yellow arrow direction.
Decrease speed: Slowly move the drive/steer control handle toward center.
Stop: Return the drive/steer control handle to center or release the foot switch.

Use the color-coded direction arrows on the platform controls and the drive chassis to identify the direction the machine will travel.



Machine travel speed is restricted when the boom is raised or extended.

Operating Instructions

Driving on a slope

Determine the uphill, downhill and side slope ratings for the machine and determine the slope grade.



Maximum slope rating,
platform downhill
(gradeability):
40% (22°)



Maximum slope rating,
platform uphill:
40% (22°)



Maximum side slope rating:
25% (14°)

Note: Slope rating is subject to ground conditions and adequate traction. The term gradeability applies to the platform downhill configuration only.

Be sure the boom is below horizontal and the platform is between the non-steer wheels.

To determine the slope grade:

Measure the slope with a digital inclinometer OR use the following procedure.

You will need:

- carpenter's level
- straight piece of wood, at least 3 feet / 1 m long
- tape measure

Lay the piece of wood on the slope.

At the downhill end, lay the level on the top edge of the piece of wood and lift the end until the piece of wood is level.

While holding the piece of wood level, measure the distance from the bottom of the piece of wood to the ground.

Divide the tape measure distance (rise) by the length of the piece of wood (run) and multiply by 100.

Example:



Piece of wood = 144 inches (3.6 m)

Run = 144 inches (3.6 m)

Rise = 12 inches (0.3 m)

$12 \text{ in} \div 144 \text{ in} = 0.083 \times 100 = 8.3\% \text{ grade}$

$0.3 \text{ m} \div 3.6 \text{ m} = 0.083 \times 100 = 8.3\% \text{ grade}$

If the slope exceeds the maximum uphill, downhill or side slope rating, then the machine must be winched or transported up or down the slope. See Transport and Lifting Instructions section.

Operating Instructions

Drive Enable

Light on indicates that the boom has moved past either circle-end wheel and drive function has been interrupted.



To drive, push the drive enable button and slowly move the drive/steer control handle off center.

If the drive/steer control handle is not moved within two seconds of pushing the drive enable button, the drive function will not operate. Release and push the drive enable button again.

Be aware that the machine may move in the opposite direction that the drive and steer controls are moved.

Always use the color-coded direction arrows on the platform controls and the drive chassis to identify the direction the machine will travel.

Engine Idle Select (rpm)

Select the engine idle (rpm) by pressing the select button. The indicator light next to the current setting will be on.



- Rabbit and foot switch symbol: foot switch activated high idle
- Turtle symbol: low idle
- Rabbit symbol: high idle

Check Engine Light



Light on and engine stopped: Tag the machine and remove from service.

Light on and engine still running: Contact service personnel within 24 hours.

Operating Envelope Indicator Lights

The operating envelope indicator lights will come on to notify the operator that a function has been interrupted and/or an action is required by the operator.

Raise Boom indicator light flashing: To continue extending the boom, raise the boom until the indicator light is off.



Retract Boom indicator light flashing: To continue lowering the boom, retract the boom until the indicator light is off.



Machine Not Level indicator light flashing: The tilt alarm will be sounding when this light is flashing. Move the machine to a firm level surface.



Platform Not Level indicator light flashing: The tilt alarm will be sounding when this light is flashing. The Platform Level toggle switch will only work in the direction that will level the platform. Level the platform until the indicator light is off.



Operating Instructions

Out of Operational Envelope Recovery

If all functions stop operating, you may have exceeded the operational envelope.

Retract Boom indicator light is flashing: Use the Auxiliary Power Unit at the platform to retract the boom until the indicator light is off. Restart the engine to continue operation.

Raise Boom indicator light is flashing: Use the Auxiliary Power Unit at the platform to raise the boom until the indicator light is off. Restart the engine to continue operation.

If the Auxiliary Power Unit at the platform does not function, a trained operator on the ground will need to lower the platform from the ground controls. Please see the Service Bypass / Recovery Key Switch section in the service manual.

Generator (if equipped)

To operate the generator, press the generator button. The indicator light will come on and the engine will continue to run.

Plug power tools into the power to platform GFCI outlet.

To turn off the generator, push the generator button. The indicator light will turn off.

After Each Use

- 1 Select a safe parking location—firm level surface, clear of obstruction and traffic.
- 2 Retract and lower the boom to the stowed position.
- 3 Rotate the turntable so that the boom is between the circle-end wheels.
- 4 Turn the key switch to the off position and remove the key to secure from unauthorized use.
- 5 Chock the wheels.

Operating Instructions

Pipe Cradle Instructions

The pipe cradle assembly consists of 2 pipe cradles positioned at either side of the platform and mounted to the guardrails with U-bolts.

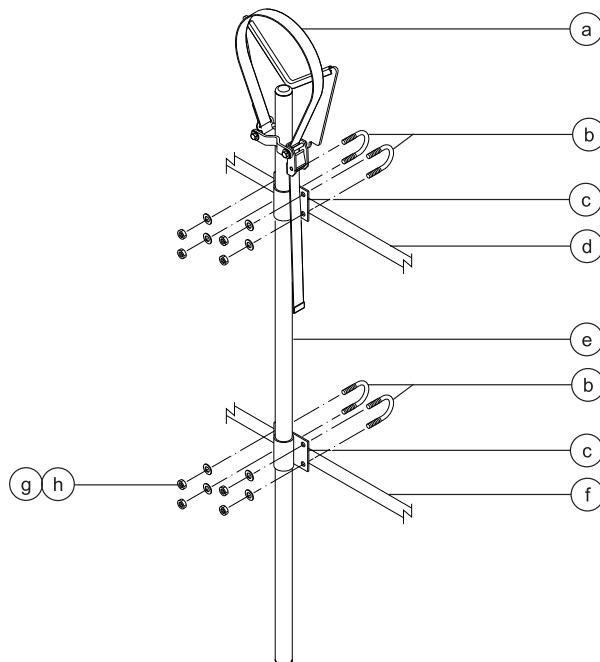

- | | |
|--------------------------|-----------------------------------|
| a strap | e pipe cradle weldment |
| b U-bolts | f middle platform railing |
| c pipe cradle mount | g flat washers |
| d upper platform railing | h $\frac{3}{8}$ -inch nylock nuts |

Observe and Obey:

- Pipe cradles must be installed on the inside of the platform.
- Pipe cradles must not obstruct the platform controls or the platform entrance.
- The bottom of the pipe cradle tube must rest on the platform floor.
- Be sure the platform is level before installing a pipe cradle.

Pipe Cradle Installation

- 1 Install a pipe cradle on each side of the platform. Refer to the illustration on the left. Make sure the bottom of the pipe cradle tube rests on the platform floor.
- 2 Install two U-bolts from the outside of the platform rails through each pipe cradle mount.
- 3 Secure each U-bolt with 2 washers and 2 nuts.

Operating Instructions

Pipe Cradle Operation

- 1 Be sure the pipe cradle assembly and installation instructions have been followed properly and that the pipe cradles are secured to the platform railings.
- 2 Place the load so that it rests in both pipe cradles. The length of the load should be parallel with the length of the platform.
- 3 Center the load in the pipe cradles.
- 4 Secure the load to each pipe cradle. Pass the nylon strap over the load. Depress the buckle and slide the strap through. Tighten the strap.
- 5 Gently push and pull on the load to make sure the pipe cradles and load are secure.
- 6 Keep the load secured when the machine is moving.

⚠ Tip-over hazard. The weight of the pipe cradle assembly and the load in the pipe cradles will reduce the rated platform capacity of the machine and must be factored into the total platform load.

⚠ Tip-over hazard. The weight of the pipe cradle assembly and the load in the pipe cradles may limit the maximum number of occupants in the platform.

Maximum Pipe Cradle Capacity	
All models	200 lbs 90.7 kg
Pipe Cradle Assembly Weight	
	21 lbs 9.5 kg

Operating Instructions

Panel Cradle Assembly

- 1 Apply the warning decal to the front of each panel cradle (if needed).
- 2 Install rubber bumper 1 in the panel cradle base. See the illustration.
- 3 Secure the bumper with 2 high profile lock nuts and 2 washers.

Panel Cradle Installation

- 1 Insert the hook piece through the slots in the panel cradle base.
- 2 Hook the panel cradle to the bottom platform tube in the desired location.
- 3 Install rubber bumper 2 through the panel cradle base and the hook piece. See the illustration.
- 4 Secure with 2 low profile lock nuts.
- 5 If the panel cradle is installed at a platform floor support tube, insert the U-bolt through the floor, around the tube and into the panel cradle base.
- 6 Secure the U-bolt with 2 nuts and 2 washers. Proceed to step 9.
- 7 If the panel cradle is not installed at a platform floor support tube, use the aluminum tube provided.
- 8 Place the tube between the panel cradle and the platform floor. Insert the U-bolt through the floor, around the tube and into the panel cradle base.
- 9 Repeat above for the second set of parts.

Installation of Padding

- 1 Install the 2 pieces of padding on the platform rails. Position the padding to protect the panels from contact with the platform rails.

Installation of Strap

- 1 Open the clamp and install it around a vertical platform rail tube.
- 2 Insert a bolt with a washer through one side of the clamp.
- 3 Install the strap assembly end plate onto the bolt.
- 4 Insert the bolt through the other side of the clamp.
- 5 Secure with a washer and a nut. Do not over-tighten. The strap assembly end plate should be able to slide on the platform rail.

Operating Instructions

Panel Cradle Operation

- 1 Secure both panel cradles to the platform.
- 2 Place the load so that it rests in both panel cradles.
- 3 Center the load on the platform.
- 4 Secure the load to the platform using the strap. Tighten the strap.

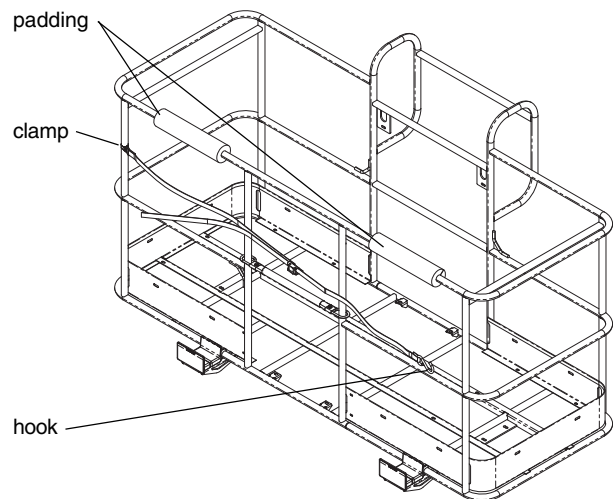
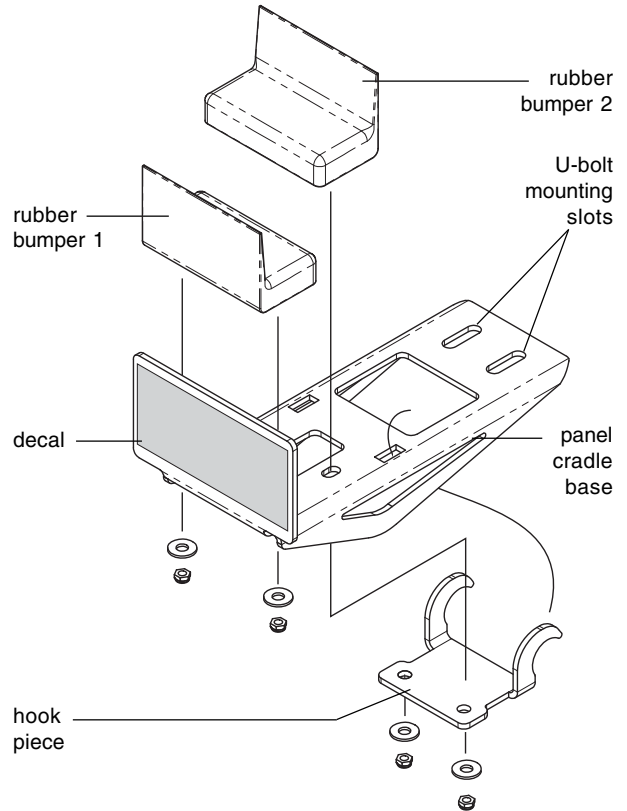

Transport and Lifting Instructions



Transport Instructions Observe and Obey:

- ☑ Genie Industries provides this securement information as a recommendation. Drivers are solely responsible for making sure machines are properly secured and the correct trailer is selected pursuant to US Department of Transportation regulations, other localized regulations, and their company policy.
- ☑ Genie customers needing to containerize any lift or Genie product should source a qualified freight forwarder with expertise in preparing, loading and securing construction and lifting equipment for international shipment.
- ☑ Only qualified aerial lift operators should move the machine on or off the truck.
- ☑ Transport vehicle must be parked on a level surface.
- ☑ Transport vehicle must be secured to prevent rolling while machine is being loaded.
- ☑ Be sure vehicle capacity, loading surfaces and chains or straps are sufficient to withstand the machine weight. Genie lifts are very heavy relative to their size. See the serial label for the machine weight. See the Decals section for the serial label location.
- ☑ Be sure the turntable is secured with the turntable rotation lock before transporting. Be sure to unlock the turntable for operation.
- ☑ Do not drive the machine on a slope that exceeds the slope or side slope rating. See Driving on a Slope in the Operating Instructions section.
- ☑ If the slope of the transport vehicle bed exceeds the uphill or downhill maximum slope rating, the machine must be loaded and unloaded using a winch as described.

Free-wheel Configuration for Winching

Chock the wheels to prevent the machine from rolling.

Release the wheel brakes by turning over all four torque hub disconnect caps.

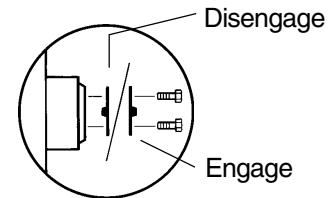

Be sure the winch line is properly secured to the drive chassis tie points and the path is clear of all obstructions.

Reverse the procedures described to re-engage the brakes.

Transport and Lifting Instructions

⚠ Securing to Truck or Trailer for Transit

Always use the turntable rotation lock pin each time the machine is transported.

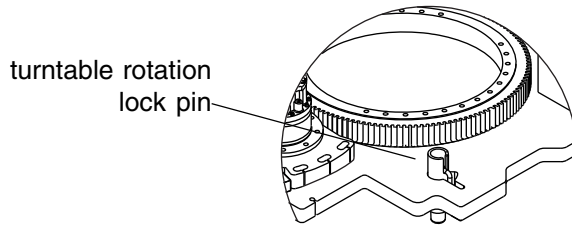

Turn the key switch to the off position and remove the key before transporting.

Inspect the entire machine for loose or unsecured items.

Securing the Chassis

Use chains of ample load capacity.

Use a minimum of 5 chains.

Adjust the rigging to prevent damage to the chains.

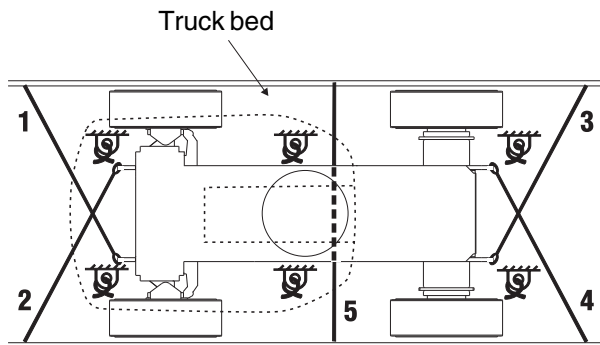

Securing the Platform - S-100 and S-120

Lower the boom to the stowed position.

Raise the platform as far as it will go (see below).

Run a strap through the platform support between the plates next to the rotator.

Anchor the strap to each corner of the truck bed.

The platform will hang over the end of the truck.

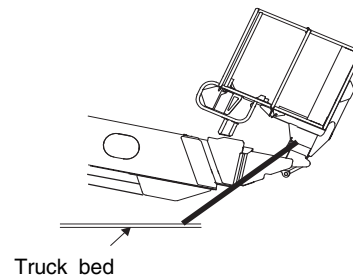

Securing the Platform - S-105 and S-125

Lower the jib to the stowed position.

Lower the platform as far as it will go, so that the jib and platform are tucked underneath the boom.

Run a strap through the platform support between the plates next to the rotator.

Anchor the strap to each corner of the truck bed.

The platform will hang over the end of the truck.

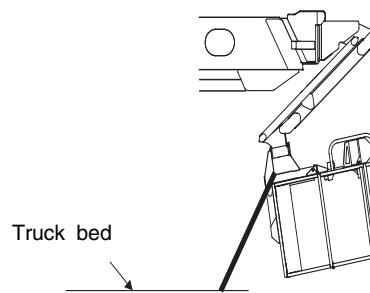

Transport and Lifting Instructions



Observe and Obey:

- ☑ Only qualified riggers should rig and lift the machine.
- ☑ Be sure the crane capacity, loading surfaces and straps or lines are sufficient to withstand the machine weight. See the serial plate for the machine weight.

Lifting Instructions

Fully lower and retract the boom. Move the jib boom (if equipped) parallel with the ground. Remove all loose items on the machine.

Use the turntable rotation lock to secure the turntable.

Determine the center of gravity of your machine using the table and the picture on this page.

Attach the rigging only to the designated lifting points on the machine. There are two lifting points on the chassis and two on the turntable.

Adjust the rigging to prevent damage to the machine and to keep the machine level.

Use a spreader bar to keep the rigging from damaging the machine.

Center of Gravity Location

	X Axis	Y Axis
S-100	6.81 ft 2.08 m	4.26 ft 1.30 m
S-105	6.62 ft 2.02 m	4.95 ft 1.51 m
S-120	6.55 ft 2.0 m	4.40 ft 1.34 m
S-125	6.32 ft 1.93 m	5.10 ft 1.55 m

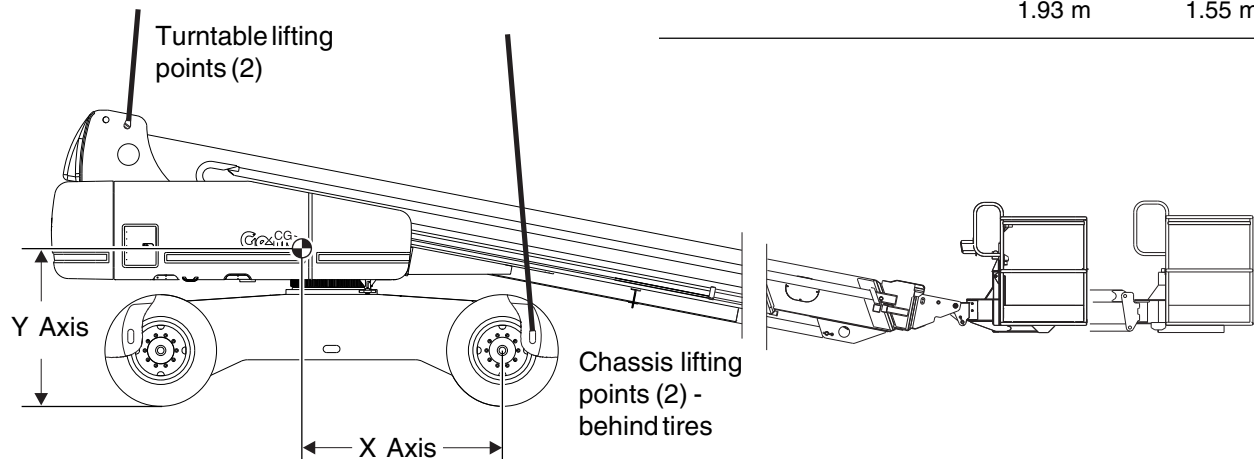

Maintenance



Observe and Obey:

- ☑ Only routine maintenance items specified in this manual shall be performed by the operator.
- ☑ Scheduled maintenance inspections shall be completed by qualified service technicians, according to the manufacturer's specifications and the requirements specified in the responsibilities manual.

Maintenance Symbols Legend

The following symbols have been used in this manual to help communicate the intent of the instructions. When one or more of the symbols appear at the beginning of a maintenance procedure, it conveys the meaning below.



Indicates that tools will be required to perform this procedure.



Indicates that new parts will be required to perform this procedure.



Indicates that a cold engine is required before performing this procedure.

Check the Engine Oil Level



Maintaining the proper engine oil level is essential to good engine performance and service life. Operating the machine with an improper oil level can damage engine components.

Note: Check the oil level with the engine off.

- 1 Check the engine oil dipstick. Add oil as needed.

Cummins B3.3C80 Engine

Oil type	15W-40
Oil type - cold conditions	10W-30

Deutz TD2011L04i Engine

Oil type	15W-40
Oil type - cold conditions	5W-30

Perkins 804D-33T Engine

Oil type	15W-40
Oil type - cold conditions	5W-40

Maintenance

Check the Hydraulic Oil Level



Maintaining the hydraulic oil at the proper level is essential to machine operation. Improper hydraulic oil levels can damage hydraulic components. Daily checks allow the inspector to identify changes in oil level that might indicate the presence of hydraulic system problems.

- 1 Be sure that the boom is in the stowed position, then visually inspect the sight gauge located on the side of the hydraulic oil tank. Add oil as needed.
- ⊙ Result: The hydraulic oil level should be within the top 2 inches / 5 cm of the sight gauge.

Hydraulic oil specifications

Hydraulic oil type	Chevron Rando equivalent
--------------------	--------------------------

Check the Batteries



Proper battery condition is essential to good engine performance and operational safety. Improper fluid levels or damaged cables and connections can result in engine component damage and hazardous conditions.

- ⚠ Electrocuting hazard. Contact with hot or live circuits may result in death or serious injury. Remove all rings, watches and other jewelry.
- ⚠ Bodily injury hazard. Batteries contain acid. Avoid spilling or contacting battery acid. Neutralize battery acid spills with baking soda and water.

Note: The controls battery is below the start battery.

- 1 Put on protective clothing and eye wear.
- 2 Be sure that the battery cable connections are tight and free of corrosion.
- 3 Be sure that the battery hold-down bar is secure.
- 4 Remove the battery vent caps.
- 5 Check the battery acid level. If needed, replenish with distilled water to the bottom of the battery fill tube. Do not overfill.
- 6 Install the vent caps.

Note: Adding terminal protectors and a corrosion preventative sealant will help eliminate corrosion on the battery terminals and cables.

Maintenance

Check the Engine Coolant Level - Liquid Cooled Models



Maintaining the engine coolant at the proper level is essential to engine service life. Improper coolant level will affect the engine's cooling capability and damage engine components. Daily checks will allow the inspector to identify changes in coolant level that might indicate cooling system problems.

⚠ Burn hazard. Beware of hot engine parts and coolant. Contact with hot engine parts and/or coolant may cause severe burns.

1 Check the fluid level in the coolant recovery tank. Add fluid as needed.

⦿ Result: The fluid level should be at the FULL mark.

Note: Do not remove the radiator cap.

Scheduled Maintenance

Maintenance performed quarterly, annually and every two years must be completed by a person trained and qualified to perform maintenance on this machine according to the procedures found in the service manual for this machine.

Machines that have been out of service for more than three months must receive the quarterly inspection before they are put back into service.

Specifications

S-100		
Height, working maximum	106 ft	32.5 m
Height, platform maximum	100 ft	30.5 m
Height, stowed maximum	10 ft 1 in	3.1 m
Horizontal reach maximum	75 ft	22.9 m
Width, axles retracted	8 ft 2 in	2.5 m
Width, axles extended	11 ft	3.35 m
Length, stowed	42 ft 8 in	13 m
Maximum load capacity	750 lbs	340 kg
Maximum wind speed	28 mph	12.5 m/s
Wheelbase	12 ft	3.7 m
Turning radius, inside, axles extended	9 ft	2.74 m
Turning radius, outside, axles extended	19 ft 10 in	6.05 m
Turning radius, inside, axles retracted	13 ft 7 in	4.14 m
Turning radius, outside, axles retracted	21 ft 7 in	6.58 m
Turntable rotation (degrees)	360°, continuous	
Turntable tailswing, axles retracted	5 ft 6 in	1.68 m
Turntable tailswing, axles extended	4 ft	1.22 m
Controls	12V DC proportional	
Platform dimensions, length x width	96 x 36 in 2.4 m x 91 cm	
Platform leveling	self-leveling	
Platform rotation	160°	
AC outlet in platform	standard	
Hydraulic pressure, maximum (drive functions)	4250 psi	293 bar
System voltage	12V	
Vibration value does not exceed 2.5 m/s ²		

Tire size, foam-filled tires	385/65 D22.5 16 ply	
Tire size, solid rubber tires	385/65 D24	
Ground clearance	14 in	35.6 cm
Fuel tank capacity	40 gallons	151 liters
Weight	39,700 lbs	18,008 kg
(Machine weights vary with option configurations)		

Drive speeds

Drive speed, stowed	3.0 mph 40 ft/9.1 sec	4.8 km/h 12.2 m/9.1 sec
Drive speed, raised or extended	0.7 mph 40 ft/40 sec	1.1 km/h 12.2 m/40 sec
Drive speed, fully extended	0.4 mph 40 ft/70 sec	0.6 km/h 12.2 m/70 sec

Maximum slope rating, stowed position

Platform downhill	40% (22°)
Platform uphill	40% (22°)
Side slope	25% (14°)

Note: Slope rating is subject to ground conditions and adequate traction.

Floor loading information

Tire load, maximum	18,650 lbs	8460 kg
Tire contact pressure	105 psi	7.4 kg/cm ² 724 kPa
Occupied floor pressure, axles extended	240 psf	1172 kg/m ² 11.5 kPa
Occupied floor pressure, axles retracted	318 psf	1552 kg/m ² 15.2 kPa

Note: Floor loading information is approximate and does not incorporate different option configurations. It should be used only with adequate safety factors.

Continuous improvement of our products is a Genie policy. Product specifications are subject to change without notice or obligation.



Specifications

S-105

Height, working maximum	111 ft	34 m
Height, platform maximum	105 ft	32 m
Height, stowed maximum	10 ft 1 in	3.1 m
Horizontal reach maximum	81 ft	24.7 m
Width, axles retracted	8 ft 2 in	2.5 m
Width, axles extended	11 ft	3.35 m
Length, stowed	46 ft	14 m
Maximum load capacity	500 lbs	227 kg
Maximum wind speed	28 mph	12.5 m/s
Wheelbase	12 ft	3.7 m
Turning radius, inside, axles extended	9 ft	2.74 m
Turning radius, outside, axles extended	19 ft 10 in	6.05 m
Turning radius, inside, axles retracted	13 ft 7 in	4.14 m
Turning radius, outside, axles retracted	21 ft 7 in	6.58 m
Turntable rotation (degrees)	360°, continuous	
Turntable tailswing, axles retracted	5 ft 6 in	1.68 m
Turntable tailswing, axles extended	4 ft	1.22 m
Controls	12V DC proportional	
Platform dimensions, length x width	96 x 36 in 2.4 m x 91 cm	
Platform leveling	self-leveling	
Platform rotation	160°	
AC outlet in platform	standard	
Hydraulic pressure, maximum (drive functions)	4250 psi	293 bar
System voltage	12V	
Vibration value does not exceed 2.5 m/s ²		

Tire size, foam-filled tires	385/65 D22.5 16 ply	
Tire size, solid rubber tires	385/65 D24	
Ground clearance	14 in	35.6 cm
Fuel tank capacity	40 gallons	151 liters
Weight	40,000 lbs	18,144 kg
(Machine weights vary with option configurations)		
Drive speed, stowed	3.0 mph 40 ft/9.1 sec	4.8 km/h 12.2 m/9.1 sec
Drive speed, raised or extended	0.7 mph 40 ft/40 sec	1.1 km/h 12.2 m/40 sec
Drive speed, fully extended	0.4 mph 40 ft/70 sec	0.6 km/h 12.2 m/70 sec

Maximum slope rating, stowed position

Platform downhill	40% (22°)
Platform uphill	40% (22°)
Side slope	25% (14°)

Note: Slope rating is subject to ground conditions and adequate traction.

Floor loading information

Tire load, maximum	21,200 lbs	9617 kg
Tire contact pressure	105 psi	7.4 kg/cm ² 724 kPa
Occupied floor pressure, axles extended	240 psf	1172 kg/m ² 11.5 kPa
Occupied floor pressure, axles retracted	318 psf	1552 kg/m ² 15.2 kPa

Note: Floor loading information is approximate and does not incorporate different option configurations. It should be used only with adequate safety factors.

Continuous improvement of our products is a Genie policy. Product specifications are subject to change without notice or obligation.



Specifications

S-120

Height, working maximum	126 ft	38.6 m
Height, platform maximum	120 ft	36.6 m
Height, stowed maximum	10 ft 1 in	3.1 m
Horizontal reach maximum	75 ft	22.9 m
Width, axles retracted	8 ft 2 in	2.5 m
Width, axles extended	11 ft	3.35 m
Length, stowed	42 ft 8 in	13 m
Maximum load capacity	750 lb	340 kg
Maximum wind speed	28 mph	12.5 m/s
Wheelbase	12 ft	3.7 m
Turning radius, inside, axles extended	8 ft 6 in	2.6 m
Turning radius, outside, axles extended	18 ft 10 in	5.7 m
Turning radius, inside, axles retracted	13 ft 2 in	4.01 m
Turning radius, outside, axles retracted	22 ft 1 in	6.7 m
Turntable rotation (degrees)	360°, continuous	
Turntable tailswing, axles retracted	5 ft 6 in	1.68 m
Turntable tailswing, axles extended	4 ft 1 in	1.24 m
Controls	12V DC proportional	
Platform dimensions, length x width	96 x 36 in 2.4 m x 91 cm	
Platform leveling	self-leveling	
Platform rotation	160°	
AC outlet in platform	standard	
Hydraulic pressure, maximum (drive functions)	4250 psi	293 bar
System voltage	12V	
Vibration value does not exceed 2.5 m/s ²		

Tire size, foam-filled tires	445/65 D22.5 18 ply	
Tire size, solid rubber tires	445/65 D24	
Ground clearance	14 in	35.6 cm
Fuel tank capacity	40 gallons	151 liters
Weight	44,340 lbs	20,112 kg
(Machine weights vary with option configurations)		

Drive speeds

Drive speed, stowed	3.0 mph 40 ft/9.1 sec	4.8 km/h 12.2 m/9.1 sec
Drive speed, raised or extended	0.7 mph 40 ft/40 sec	1.1 km/h 12.2 m/40 sec
Drive speed, fully extended	0.4 mph 40 ft/70 sec	0.6 km/h 12.2 m/70 sec

Maximum slope rating, stowed position

Platform downhill	40% (22°)
Platform uphill	40% (22°)
Side slope	25% (14°)

Note: Slope rating is subject to ground conditions and adequate traction.

Floor loading information

Tire load, maximum	21,250 lbs	9639 kg
Tire contact pressure	105 psi	7.4 kg/cm ² 724 kPa
Occupied floor pressure, axles extended	266 psf	1299 kg/m ² 12.7 kPa
Occupied floor pressure, axles retracted	353 psf	1723 kg/m ² 16.9 kPa

Note: Floor loading information is approximate and does not incorporate different option configurations. It should be used only with adequate safety factors.

Continuous improvement of our products is a Genie policy. Product specifications are subject to change without notice or obligation.



Specifications

S-125

Height, working maximum	131 ft	40.1 m
Height, platform maximum	125 ft	38.1 m
Height, stowed maximum	10 ft 1 in	3.1 m
Horizontal reach maximum	80 ft	24.4 m
Width, axles retracted	8 ft 2 in	2.5 m
Width, axles extended	11 ft	3.35 m
Length, stowed	46 ft 9 in	14.2 m
Maximum load capacity	500 lb	227 kg
Maximum wind speed	28 mph	12.5 m/s
Wheelbase	12 ft	3.7 m
Turning radius, inside, axles extended	8 ft 6 in	2.6 m
Turning radius, outside, axles extended	18 ft 10 in	5.7 m
Turning radius, inside, axles retracted	13 ft 2 in	4.01 m
Turning radius, outside, axles retracted	22 ft 1 in	6.7 m
Turntable rotation (degrees)	360°, continuous	
Turntable tailswing, axles retracted	5 ft 6 in	1.68 m
Turntable tailswing, axles extended	4 ft 1 in	1.24 m
Controls	12V DC proportional	
Platform dimensions, length x width	96 x 36 in 2.4 m x 91 cm	
Platform leveling	self-leveling	
Platform rotation	160°	
AC outlet in platform	standard	
Hydraulic pressure, maximum (drive functions)	4250 psi	293 bar
System voltage	12V	
Vibration value does not exceed 2.5 m/s ²		

Tire size, foam-filled tires	445/65 D22.5 18 ply	
Tire size, solid rubber tires	445/65 D24	
Ground clearance	14 in	35.6 cm
Fuel tank capacity	40 gallons	151 liters
Weight	44,640 lbs	20,248 kg
(Machine weights vary with option configurations)		

Drive speeds

Drive speed, stowed	3.0 mph 40 ft/9.1 sec	4.8 km/h 12.2 m/9.1 sec
Drive speed, raised or extended	0.7 mph 40 ft/40 sec	1.1 km/h 12.2 m/40 sec
Drive speed, fully extended	0.4 mph 40 ft/70 sec	0.6 km/h 12.2 m/70 sec

Maximum slope rating, stowed position

Platform downhill	40% (22°)
Platform uphill	40% (22°)
Side slope	25% (14°)

Note: Slope rating is subject to ground conditions and adequate traction.

Floor loading information

Tire load, maximum	23,750 lbs	10,773 kg
Tire contact pressure	105 psi	7.4 kg/cm ² 724 kPa
Occupied floor pressure, axles extended	265 psf	1294 kg/m ² 12.7 kPa
Occupied floor pressure, axles retracted	353 psf	1723 kg/m ² 16.9 kPa

Note: Floor loading information is approximate and does not incorporate different option configurations. It should be used only with adequate safety factors.

Continuous improvement of our products is a Genie policy. Product specifications are subject to change without notice or obligation.



Specifications

S-100 Range of Motion Chart

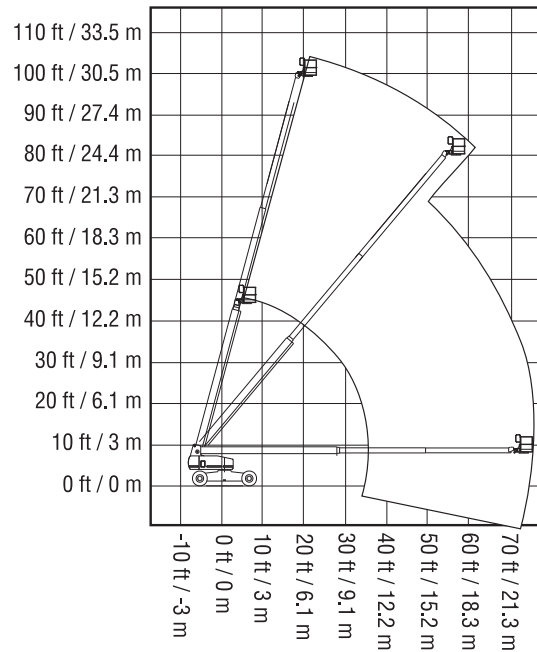

S-105 Range of Motion Chart

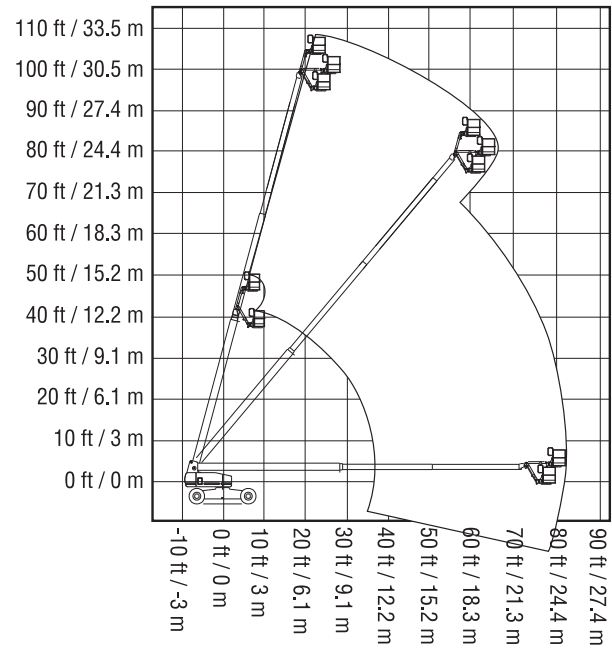

S-120 Range of Motion Chart

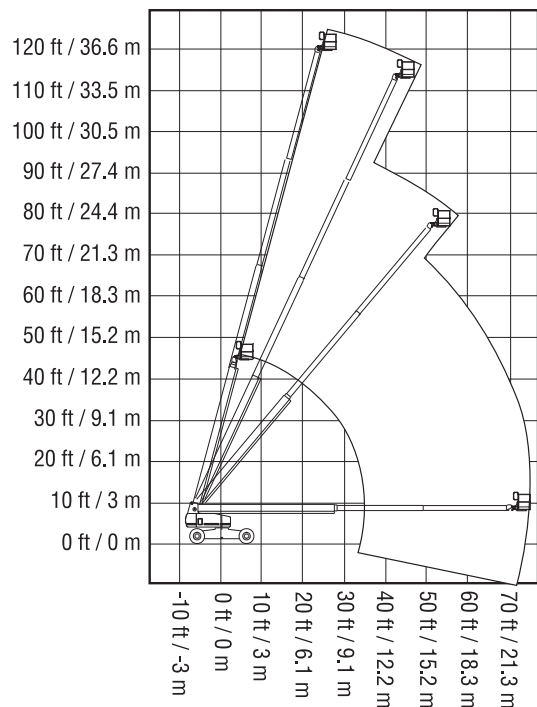

S-125 Range of Motion Chart

